

OCT 24 2018

Received

Contract Routing Form

ROUTING: Urgent Rush

printed on: 10/22/2018

Contract between: Raymond P Cattell Inc
and Dept. or Division: Engineering Division
Name/Phone Number:

Project: McPike Park - Skatepark Seating Area

Contract No.: 8273
Enactment No.: RES-18-00727
Dollar Amount: 47,020.00

File No.: 53195
Enactment Date: 10/16/2018

(Please DATE before routing)

Signatures Required	Date Received	Date Signed
City Clerk	10-23-18	10-23-18
Director of Civil Rights	10-30-18	10-30-18 FNS
Risk Manager	10/30/18	10/30/18 RN
Finance Director	10-30-2018	10/30/18 MCR
City Attorney	1197 10-31-18	11-01-18
Mayor	11/2/2018	11/2/2018 ed

Please return signed Contracts to the City Clerk's Office
Room 103, City-County Building for filing.

Original + 2 Copies

10/22/2018 11:57:36 enjls - Mike Sturm
10/22/2018 11:58:26 enjls - Please route on RUSH/Hand Carry status. When contract is signed and ready to continue routing, please call Engineering, 266-4751, for Heidi or Johanna to pick up. Thank you.

Dis Rights: OK / N/A / Problem - Hold
Prev Wage: AA / Agency / No
Contract Value: 47,020.00
AA Plan: Approved
Amendment / Addendum # N/A
Type: POS / Dvlp / Sbdv / Gov't / Grant PW / Goal / Loan / Agrmt

[Sign In](#)

[Legislative Information Center Home](#) [Legislation](#) [Meetings](#) [Common Council](#)
[Boards, Commissions and Committees](#) [Members](#)

   [Share](#)  [RSS](#)  [Alerts](#)

[Details](#) [Reports](#)

File #:	53195	Version: 1	Name:	Awarding Public Works Contract No. 8273, McPike Park - Skatepark Seating Area.
Type:	Resolution		Status:	Passed
File created:	9/14/2018		In control:	Engineering Division
On agenda:	10/16/2018		Final action:	10/16/2018
Enactment date:	10/18/2018		Enactment #:	RES-18-00727
Title:	Awarding Public Works Contract No. 8273, McPike Park - Skatepark Seating Area. (6th AD)			
Sponsors:	BOARD OF PUBLIC WORKS			
Attachments:	1. Contract 8273.pdf			

[History \(4\)](#) [Text](#)

Fiscal Note

The proposed resolution authorizes the award of Public Works Contract No. 8273, McPike Park - Skatepark Seating Area. The total estimated cost of the project is \$50,780 and will be funded by a grant (\$23,510) and City funds (\$27,270). Grant funding is available in the Central Park Project (Munis 10646). Funding for the City match is available in the Park Land Improvements Project (Munis 17557).

Title

Awarding Public Works Contract No. 8273, McPike Park - Skatepark Seating Area. (6th AD)

Body

BE IT RESOLVED, that the following low bids for miscellaneous improvements be accepted and that the Mayor and City Clerk be and are hereby authorized and directed to enter into a contract with the low bidders contained herein, subject to the Contractor's compliance with Section 39.02 of the Madison General Ordinances concerning compliance with the Affirmative Action provisions **and subject to the Contractor's compliance with Section 33.07 of the Madison General Ordinances regarding Best Value Contracting:**

BE IT FURTHER RESOLVED, that the funds be encumbered to cover the cost of the projects contained herein.

See attached document (Contract No. 8273) for itemization of bids.



PROJECT _____ CONTRACTOR _____ AMOUNT OF BID _____

CONTRACT NO. 8273
MCPIKE PARK – SKATEPARK SEATING AREA

RAYMOND P. CATTELL, INC.

\$47,020.00

Acct. No. 10524-51-130

\$23,510.00

Acct. No. 17557-51-130

\$23,510.00

Contingency 8±

3,760.00

Sub-Total

\$27,270.00

GRAND TOTAL

\$50,780.00

Jurisdiction: Wisconsin

Demographics

Company Name: Ohio Casualty Insurance Company, The
Short Name:
SBS Company Number: 54218499
NAIC CoCode: 24074
FEIN: 31-0396250
Domicile Type: Foreign
State of Domicile: New Hampshire
Country of Domicile: United States
NAIC Group Number: 111 - LIBERTY MUT GRP
Organization Type: Stock
Date of Incorporation: 01/01/1919
Merger Flag: No

Address

Business Address

62 MAPLE AVE
 KEENE, NH 03431-1625
 United States

Mailing Address

175 BERKELEY ST
 BOSTON, MA 02116
 United States

Statutory Home Office Address

62 MAPLE AVE
 KEENE, NH 03431-1625
 United States

Main Administrative Office Address

175 BERKELEY ST
 BOSTON, MA 02116
 United States

Phone, E-mail, Website

Phone

Type	Number
Fax Phone	(617) 574-5955
Toll Free Phone	(800) 843-6446
Business Primary Phone	(617) 357-9500

Email

No results found.

Website

No results found.

Company Type

Company Type: Property and Casualty

© 2018 National Association of Insurance Commissioners. All rights reserved.

Status: Active
Status Reason:
Status Date: 08/02/1929
Effective Date: 10/01/2012
Legacy State ID: 110565
Issue Date: 08/02/1929
Approval Date:
File Date:
Articles of Incorporation Received: No
Article No:
COA Number:

Appointments

Export to Excel

zahn

Licensee Name	License Number	NPN	License Type	Line of Authority	Appointment Date	Effective Date	Expiration Date
JAY ZAHN	2181567	2181567	Intermediary (Agent) Individual	Casualty	03/16/2015	03/16/2018	03/15/2019
MICHAEL ZAHN	14840439	14840439	Intermediary (Agent) Individual	Casualty	03/25/2015	03/16/2018	03/15/2019

Line Of Business

Filter

Line of Business	Citation Type	Effective Date
Aircraft	Aircraft	08/02/1929
Automobile	Automobile	08/02/1929
Credit Insurance	Credit Insurance	08/02/1929
Disability Insurance	Disability Insurance	08/02/1929
Fidelity Insurance	Fidelity Insurance	08/02/1929
Fire, Inland Marine and Other Property Insurance	Fire, Inland Marine and Other Property Insurance	08/02/1929
Liability and Incidental Medical Expense Insurance (other than automobile)	Liability and Incidental Medical Expense Insurance (other than automobile)	08/02/1929
Miscellaneous	Miscellaneous	08/02/1929
Ocean Marine Insurance	Ocean Marine Insurance	08/02/1929
Surety Insurance	Surety Insurance	08/02/1929

Contact

Filter

Contact Type	Preferred Name	Name	E-mail	Phone	Address
Registered Agent for Service of Process		*			Other CORPORATION SERVICE COMPANY 8040 EXCELSIOR DR STE 400 MADISON, WI 53717 United States

Company Merger

No results found.

Name Change History

Filter

Previous Name	New Name	Effective Date
	Ohio Casualty Insurance Company, The	

\$47,020.00
FILE

BID OF RAYMOND P. CATTELL, INC.

2018

PROPOSAL, CONTRACT, BOND AND SPECIFICATIONS

FOR

MCPIKE PARK – SKATEPARK SEATING AREA

CONTRACT NO. 8273

MUNIS NO. 10524 -51 -130

IN

MADISON, DANE COUNTY, WISCONSIN

AWARDED BY THE COMMON COUNCIL
MADISON, WISCONSIN ON OCTOBER 16, 2018

CITY ENGINEERING DIVISION
1600 EMIL STREET
MADISON, WISCONSIN 53713

<https://bidexpress.com/login>

**MCPIKE PARK - SKATEPARK SEATING AREA
CONTRACT NO. 8273**

INDEX

SECTION A: ADVERTISEMENT FOR BIDS AND INSTRUCTIONS TO BIDDERS	A-1
SECTION B: PROPOSAL SECTION.....	B-1
SECTION C: SMALL BUSINESS ENTERPRISE (NOT APPLICABLE)	C-1
SECTION D: SPECIAL PROVISIONS.....	D-1
SECTION E: BIDDER'S ACKNOWLEDGEMENT	E-1
SECTION F: BEST VALUE CONTRACTING	F-1
SECTION G: BID BOND.....	G-1
SECTION H: AGREEMENT.....	H-1
SECTION I: PAYMENT AND PERFORMANCE BOND	I-1

This Proposal, and Agreement have
been prepared by:

**PARKS DIVISION
CITY OF MADISON
MADISON, DANE COUNTY, WISCONSIN**

Eric Knepp, Parks Superintendent

EK: MS

SECTION A: ADVERTISEMENT FOR BIDS AND INSTRUCTIONS TO BIDDERS

REQUEST FOR BID FOR PUBLIC WORKS CONSTRUCTION CITY OF MADISON, WISCONSIN

A BEST VALUE CONTRACTING MUNICIPALITY

PROJECT NAME:	MCPIKE PARK - SKATEPARK SEATING AREA
CONTRACT NO.:	8273
BID BOND	5%
PREQUALIFICATION APPLICATION DUE (2:00 P.M.)	09/13/18
BID SUBMISSION (2:00 P.M.)	09/20/18
BID OPEN (2:30 P.M.)	09/20/18
PUBLISHED IN WSJ	8/30/18, 9/06/18 & 9/13/18

PREQUALIFICATION APPLICATION: Forms are available at the same location or on our website, www.cityofmadison.com/business/pw/forms.cfm. If not currently prequalified in the categories listed in Section A, an amendment to your Prequalification will need to be submitted prior to the same due date. Postmark is not applicable.

BIDS TO BE SUBMITTED by hand to 1600 EMIL ST., MADISON, WI 53713 or online at www.bidexpress.com.

THE BID OPENING is at 1600 EMIL ST., MADISON, WI 53713.

STANDARD SPECIFICATIONS

The City of Madison's Standard Specifications for Public Works Construction - 2018 Edition, as supplemented and amended from time to time, forms a part of these contract documents as if attached hereto.

These standard specifications are available on the City of Madison Public Works website, www.cityofmadison.com/Business/PW/specs.cfm.

The Contractor shall review these Specifications prior to preparation of proposals for the work to be done under this contract, with specific attention to Article 102, "BIDDING REQUIREMENTS AND CONDITIONS" and Article 103, "AWARD AND EXECUTION OF THE CONTRACT." For the convenience of the bidder, below are highlights of three subsections of the specifications.

SECTION 102.1: PRE-QUALIFICATION OF BIDDERS

In accordance with Wisconsin State Statutes 66.0901 (2) and (3), all bidders must submit to the Board of Public Works proof of responsibility on forms furnished by the City. The City requires that all bidders be qualified on a biennial basis.

Bidders must present satisfactory evidence that they have been regularly engaged in the type of work specified herein and they are fully prepared with necessary capital, materials, machinery and supervisory personnel to conduct the work to be contracted for to the satisfaction of the City. All bidders must be pre-qualified by the Board of Public Works for the type of construction on which they are bidding prior to the opening of the bid.

In accordance with Section 39.02(9)(a)l. of the General Ordinances, all bidders shall submit in writing to the Affirmative Action Division Manager of the City of Madison, a Certificate of Compliance or an Affirmative Action Plan at the same time or prior to the submission of the proof of responsibility forms.

The bidder shall be disqualified if the bidder fails to or refuses to, prior to opening of the bid, submit a Certificate of compliance, Affirmative Action Plan or Affirmative Action Data Update, as applicable, as defined by Section 39.02 of the General Ordinances (entitled Affirmative Action) and as required by Section 102.11 of the Standard Specifications.

SECTION 102.4 PROPOSAL

No bid will be accepted that does not contain an adequate or reasonable price for each and every item named in the Schedule of Unit Prices.

A lump sum bid for the work in accordance with the plans and specifications is required. The lump sum bid must be the same as the total amounts bid for the various items and it shall be inserted in the space provided.

All papers bound with or attached to the proposal form are considered a part thereof and must not be detached or altered when the proposal is submitted. The plans, specifications and other documents designated in the proposal form will be considered a part of the proposal whether attached or not.

A proposal submitted by an individual shall be signed by the bidder or by a duly authorized agent. A proposal submitted by a partnership shall be signed by a member/partner or by a duly authorized agent thereof. A proposal submitted by a corporation shall be signed by an authorized officer or duly authorized registered agent of such corporation, and the proposal shall show the name of the State under the laws of which such corporation was chartered. The required signatures shall in all cases appear in the space provided thereof on the proposal.

Each proposal shall be placed, together with the proposal guaranty, in a sealed envelope, so marked as to indicate name of project, the contract number or option to which it applies, and the name and address of the Contractor or submitted electronically through Bid Express (www.bidexpress.com). Proposals will be accepted at the location, the time and the date designated in the advertisement. Proposals received after the time and date designated will be returned to the bidder unopened.

SECTION 102.5: BID DEPOSIT (PROPOSAL GUARANTY)

All bids, sealed or electronic, must be accompanied with a Bid Bond equal to at least 5% of the bid or a Certificate of Annual/Biennial Bid Bond or certified check, payable to the City Treasurer. Bid deposit of the successful bidders shall be returned within forty-eight (48) hours following execution of the contract and bond as required.

MINOR DISCREPENCIES

Bidder is responsible for submitting all forms necessary for the City to determine compliance with State and City bidding requirements. Notwithstanding any language to the contrary contained herein, the City may exercise its discretion to allow bidders to correct or supplement submissions after bid opening, if the minor discrepancy, bid irregularity or omission is insignificant and not one related to price, quality, quantity, time of completion or performance of the contract.

Bidders for this Contract(s) must be Pre-Qualified for at least one of the following type(s) of construction denoted by an

Building Demolition

- | | |
|---|--|
| 101 <input type="checkbox"/> Asbestos Removal | 110 <input type="checkbox"/> Building Demolition |
| 120 <input type="checkbox"/> House Mover | |

Street, Utility and Site Construction

- | | |
|---|--|
| 201 <input type="checkbox"/> Asphalt Paving | 265 <input type="checkbox"/> Retaining Walls, Precast Modular Units |
| 205 <input type="checkbox"/> Blasting | 270 <input type="checkbox"/> Retaining Walls, Reinforced Concrete |
| 210 <input type="checkbox"/> Boring/Pipe Jacking | 275 <input type="checkbox"/> Sanitary, Storm Sewer and Water Main Construction |
| 215 <input checked="" type="checkbox"/> Concrete Paving | 276 <input type="checkbox"/> Sawcutting |
| 220 <input checked="" type="checkbox"/> Con. Sidewalk/Curb & Gutter/Misc. Flat Work | 280 <input type="checkbox"/> Sewer Lateral Drain Cleaning/Internal TV Insp. |
| 221 <input checked="" type="checkbox"/> Concrete Bases and Other Concrete Work | 285 <input type="checkbox"/> Sewer Lining |
| 222 <input type="checkbox"/> Concrete Removal | 290 <input type="checkbox"/> Sewer Pipe Bursting |
| 225 <input type="checkbox"/> Dredging | 295 <input type="checkbox"/> Soil Borings |
| 230 <input type="checkbox"/> Fencing | 300 <input type="checkbox"/> Soil Nailing |
| 235 <input type="checkbox"/> Fiber Optic Cable/Conduit Installation | 305 <input type="checkbox"/> Storm & Sanitary Sewer Laterals & Water Svc. |
| 240 <input checked="" type="checkbox"/> Grading and Earthwork | 310 <input type="checkbox"/> Street Construction |
| 241 <input type="checkbox"/> Horizontal Saw Cutting of Sidewalk | 315 <input type="checkbox"/> Street Lighting |
| 242 <input type="checkbox"/> Infrared Seamless Patching | 318 <input type="checkbox"/> Tennis Court Resurfacing |
| 245 <input type="checkbox"/> Landscaping, Maintenance | 320 <input type="checkbox"/> Traffic Signals |
| 246 <input type="checkbox"/> Ecological Restoration | 325 <input type="checkbox"/> Traffic Signing & Marking |
| 250 <input checked="" type="checkbox"/> Landscaping, Site and Street | 332 <input type="checkbox"/> Tree pruning/removal |
| 251 <input type="checkbox"/> Parking Ramp Maintenance | 333 <input type="checkbox"/> Tree, pesticide treatment of |
| 252 <input type="checkbox"/> Pavement Marking | 335 <input type="checkbox"/> Trucking |
| 255 <input type="checkbox"/> Pavement Sealcoating and Crack Sealing | 340 <input type="checkbox"/> Utility Transmission Lines including Natural Gas, Electrical & Communications |
| 260 <input type="checkbox"/> Petroleum Above/Below Ground Storage Tank Removal/Installation | 399 <input type="checkbox"/> Other _____ |
| 262 <input type="checkbox"/> Playground Installer | |

Bridge Construction

- 501 Bridge Construction and/or Repair

Building Construction

- | | |
|--|---|
| 401 <input type="checkbox"/> Floor Covering (including carpet, ceramic tile installation, rubber, VCT) | 437 <input type="checkbox"/> Metals |
| 402 <input type="checkbox"/> Building Automation Systems | 440 <input type="checkbox"/> Painting and Wallcovering |
| 403 <input type="checkbox"/> Concrete | 445 <input type="checkbox"/> Plumbing |
| 404 <input type="checkbox"/> Doors and Windows | 450 <input type="checkbox"/> Pump Repair |
| 405 <input type="checkbox"/> Electrical - Power, Lighting & Communications | 455 <input type="checkbox"/> Pump Systems |
| 410 <input type="checkbox"/> Elevator - Lifts | 460 <input type="checkbox"/> Roofing and Moisture Protection |
| 412 <input type="checkbox"/> Fire Suppression | 464 <input type="checkbox"/> Tower Crane Operator |
| 413 <input type="checkbox"/> Furnishings - Furniture and Window Treatments | 461 <input type="checkbox"/> Solar Photovoltaic/Hot Water Systems |
| 415 <input type="checkbox"/> General Building Construction, Equal or Less than \$250,000 | 465 <input type="checkbox"/> Soil/Groundwater Remediation |
| 420 <input type="checkbox"/> General Building Construction, \$250,000 to \$1,500,000 | 466 <input type="checkbox"/> Warning Sirens |
| 425 <input type="checkbox"/> General Building Construction, Over \$1,500,000 | 470 <input type="checkbox"/> Water Supply Elevated Tanks |
| 428 <input type="checkbox"/> Glass and/or Glazing | 475 <input type="checkbox"/> Water Supply Wells |
| 429 <input type="checkbox"/> Hazardous Material Removal | 480 <input type="checkbox"/> Wood, Plastics & Composites - Structural & Architectural |
| 430 <input type="checkbox"/> Heating, Ventilating and Air Conditioning (HVAC) | 499 <input type="checkbox"/> Other _____ |
| 433 <input type="checkbox"/> Insulation - Thermal | |
| 435 <input type="checkbox"/> Masonry/Tuck pointing | |

State of Wisconsin Certifications

- 1 Class 5 Blaster - Blasting Operations and Activities 2500 feet and closer to inhabited buildings for quarries, open pits and road cuts.
- 2 Class 6 Blaster - Blasting Operations and Activities 2500 feet and closer to inhabited buildings for trenches, site excavations, basements, underwater demolition, underground excavations, or structures 15 feet or less in height.
- 3 Class 7 Blaster - Blasting Operations and Activities for structures greater than 15' in height, bridges, towers, and any of the objects or purposes listed as "Class 5 Blaster or Class 6 Blaster".
- 4 Petroleum Above/Below Ground Storage Tank Removal and Installation (Attach copies of State Certifications.)
- 5 Hazardous Material Removal (Contractor to be certified for asbestos and lead abatement per the Wisconsin Department of Health Services, Asbestos and Lead Section (A&LS).) See the following link for application: www.dhs.wisconsin.gov/Asbestos/Cert. State of Wisconsin Performance of Asbestos Abatement Certificate must be attached.
- 6 Certification number as a Certified Arborist or Certified Tree Worker as administered by the International Society of Arboriculture
- 7 Pesticide application (Certification for Commercial Applicator For Hire with the certification in the category of turf and landscape (3.0) and possess a current license issued by the DATCP)
- 8 State of Wisconsin Master Plumbers License.

SECTION B: PROPOSAL

Please refer to the
Bid Express Website
at <https://bidexpress.com>
look up contract number
and go to
Section B: Proposal Page

You can access all City of Madison bid solicitations for FREE at www.bidexpress.com

Click on the "Register for Free" button and follow the instructions to register your company and yourself. You will be asked for a payment subscription preference, since you may wish to bid online someday. Simply choose the method to pay on a 'per bid' basis. This requires no payment until / unless you actually bid online. You can also choose the monthly subscription plan at this time. You will, however, be asked to provide payment information. Remember, you can change your preference at anytime. You will then be able to complete your free registration and have full access to the site. Your free access does not require completion of the 'Digital ID' process, so you will have instant access for viewing and downloading. To be prepared in case you ever do wish to bid online, you may wish to establish your digital ID also, since you cannot bid without a Digital ID.

If you have any problems with the free registration process, you can call the bidexpress help team, toll free at 1-888-352-2439 (option 1, option1).

SECTION C: SMALL BUSINESS ENTERPRISE

**Instructions to Bidders
City of Madison
SBE Program Information**

SBE NOT APPLICABLE

SECTION D: SPECIAL PROVISIONS

MCPIKE PARK - SKATEPARK SEATING AREA CONTRACT NO. 8273

It is the intent of these Special Provisions to set forth the final contractual intent as to the matter involved and shall prevail over the Standard Specifications and plans whenever in conflict therewith. In order that comparisons between the Special Provisions can be readily made, the numbering system for the Special Provisions is equivalent to that of the Specifications.

Whenever in these Specifications the term "Standard Specifications" appears, it shall be taken to refer to the City of Madison Standard Specifications for Public Works Construction and Supplements thereto.

SECTION 102.11: BEST VALUE CONTRACTING

This Contract shall be considered a Best Value Contract if the Contractor's bid is equal to or greater than \$61,000 for a single trade contract; or equal to or greater than \$297,500 for a multi-trade contract pursuant to MGO 33.07(7).

SECTION 102.12: EQUAL BENEFITS REQUIREMENT (SEC. 39.07, MGO)

Equal Benefits are not required. Delete this entire provision.

ARTICLE 104: SCOPE OF WORK

This project consists of installation of a concrete slab, assembly and installation of pre-fabricated bleachers, temporary removal and replacement of existing fencing, installation of new fencing and boulder retaining wall and associated sitework at McPike Park adjacent to an existing skatepark.

The Contractor shall view the site prior to bidding to become familiar with the existing conditions. The Contractor shall work with the existing utilities to resolve conflicts during the construction process.

The design and ordering of the pre-fabricated bleachers is excluded from the scope of this work.

SECTION 104.4: INCREASED OR DECREASED QUANTITIES

It is agreed and understood that the quantities of any items of work shown on the plans or in the proposal are subject to increase or decrease during the progress of the work. The Engineer reserves the right to increase or decrease the quantities of any items of work, including increase or decrease of quantities by alteration of plans, as may be considered necessary or desirable during the progress of the work to satisfactorily complete the project. Such increases or decreases in quantities shall not be considered as a waiver of any conditions of the contract nor invalidate any of the provisions thereof. All terms of Section 104.5 Increase Items and Section 104.6 Decreased and Deleted Items of the Standard Specifications for Public Works Construction are applicable to this project.

SECTION 101.5: AUTHORITY OF THE ENGINEER

The Engineer shall resolve all questions which arise as to the quality and acceptability of materials furnished, work performed, manner of performance, rate of progress of the work, interpretation of the plans and Specifications, acceptable fulfillment of the contract, compensation, and disputes and mutual rights between Contractors under the Specifications. The Engineer shall determine the amount and quantity of work performed and materials furnished.

All decisions of the Engineer shall, when so requested, be rendered in writing. They shall be final and conclusive in all matters unless within ten (10) days after such decision the Contractor applies in writing to the Board of Public Works for a review of such decision.

SECTION 105.9: SURVEYS, POINTS, AND INSTRUCTION

The Contractor is responsible for the layout of proposed bleacher seating area and retaining wall per Bid Item 20130. The Contractor shall contact Parks Surveyor Dan Rodman at 658-3087 at least 48 hours prior to proof subgrade elevations prior to paving. Any questions regarding the layout and staking of this project should be directed to Dan Rodman at the number above.

SECTION 101.52: COOPERATION BY CONTRACTOR

Several utilities exist on the site. The Contractor shall perform a One Call through Digger's Hotline for the site at least three days prior to beginning construction. To ensure that Parks-owned utilities are also marked, include the PARK NAME AT THE BEGINNING OF THE MARKING instructions field on the ticket, and send a copy of the ticket to the City of Madison Parks Surveyor (Dan Rodman / drodman@cityofmadison.com / tel (608) 658-3087/ fax (608)267-1162).

Among the utilities present there is also an extensive lawn irrigation system in the Great Lawn area that has shallow water service lines to the irrigation heads. The facilities listed are not intended to be a complete list of the facilities located in the vicinity of the project site. Utilities located outside of the project limits are not anticipated to be in conflict with construction. Contact information for the known utilities are provided for the Contractor's reference, below:

MG&E-Electric

Contact: Chris Erickson
P.O. Box 1231
Madison, WI 53701
Phone: 608-252-5670
Cell: 608-516-7940
Email: cerickson@mge.com

MG&E-Gas

Contact: Sean Endres
P.O. Box 1231
Madison, WI 53701
Phone: 608-252-7224
Email: sendres@mge.com

Wisconsin DOA

Contact: Lisa Gilbert
Email: lisa.gilbert@wisconsin.gov

MCI Communications

Contact: Steve Bonczkowski
Phone: 630-327-6959
Email: Stephen.bonczkowski@verizon.com

American Transmission Company

Contact: Lori Kolbow
2 Fen Oak Court
Madison, WI 53718
Phone: 608-877-7158
Email: lkolbow@atcllc.com

Madison Metropolitan Sewerage District

Contact: Eric Hjellen
1610 Moorland Road
Madison, WI 53713
Phone: 608-222-1201 Ext. 348

Cell: 608-347-3613
Email: erich@madsewer.org

The Contractor shall attend a pre-construction meeting prior to the start of construction.

McPike Park has known, isolated zones of petroleum-contaminated soils located at the west end of the project site with contaminated industrial fill located elsewhere within the park. These contaminants have been contained with a 2-foot cap of topsoil and clean fill.

Contractor must notify Brynn Bemis at City Engineering (608) 267-1986 or bbemis@cityofmadison.com a minimum of 36 hours prior to beginning excavation work at the site.

The Contractor warrants that its services are performed, within the limits prescribed by the City, with the usual thoroughness and competence of the consulting profession; in accordance with the standard for professional services at the time those services are rendered. The Contractor shall be responsible for the accuracy of the work performed under this Agreement, and shall promptly make necessary revisions or corrections resulting from their negligent acts, errors or omissions without additional compensation. The Contractor shall be responsible for any damages incurred as a result of their errors, omissions, or negligent acts and for any losses or costs to repair or remedy construction.

The Contractor shall take care when accessing the site not to damage the existing utilities, concrete skate park surface, curb, sidewalk or asphalt pavement. Any damage shall be repaired by the Contractor per the Standard Specifications and considered incidental to this contract.

The Contractor will be allowed to store equipment and materials on site as shown on the drawings, with the exact location to be determined at the pre construction meeting. The Contractor shall secure materials at the end of each work day to deter any potential vandalism and theft. The Contractor is responsible for securing all equipment and materials at the end of each work day.

McPike Park is a well-used park that will remain open during the construction time period. Caution should be taken entering and exiting the park area.

The skatepark will also remain open during construction. The Contractor shall limit site access to the route identified in the plans. **Access through the existing skatepark is not permitted.**

SECTION 101.53: ORDER OF COMPLETION

Prior to beginning construction, the Contractor shall submit to the City a detailed schedule showing the sequence and anticipated dates of all construction operations.

SECTION 108.2: PERMITS

The following permits will be applied for by the City of Madison for the site:

1. City of Madison Erosion Control Permit

City of Madison staff shall be responsible for erosion control permit reporting, as needed. The Contractor shall meet the conditions of all permits and must keep a copy of each individual permit on site at all times throughout construction.

The Contractor is responsible for cleaning any material tracked into the existing park path or street. Street sweeping shall be paid as a Bid Item 21013.

The Contractor shall meet the conditions of the permits including properly installing and maintaining the erosion control measures shown on the plans, specified in these special provisions, or as directed by the Engineer or his designees.

The City's obtaining these permits is not intended to be exhaustive of all permits that may be required to be obtained by the Contractor for construction of this project. It shall be the responsibility of the Contractor to identify and obtain any other permits needed for construction.

SECTION 109.2: PROSECUTION OF THE WORK

Work cannot start on this contract until after the "Start to Work" letter has been received. Construction work must begin within seven (7) calendar days after the date appearing on the mailed notice to do so that was sent to the Contractor. Construction work shall be carried at a rate so as to secure full completion within the contract times outlined in Section 109.7, the rate of progress and the time of completion being essential conditions of this Agreement. Definite notice of intention to start work shall be given to the Engineer at least seventy-two (72) hours in advance of beginning work.

The fixed, agreed upon, liquidated damages for failure to complete all work within the contract, unless otherwise specified in this section, shall be calculated in accordance with Article 109 of the Standard Specifications. The Contractor shall limit workdays from 7:00 am to 7:00 pm, Monday - Friday, unless approved by the Engineer in writing.

SECTION 109.7: TIME OF COMPLETION

The Contractor shall begin work on the McPike Park Skatepark Seating Area contract on or before November 2, 2018 and shall be substantially completed by December 31, 2018.

SECTION 110.1: MEASUREMENT OF QUANTITIES

All bid items listed in the proposal page will be paid for at the quantity listed in the proposal page, and will not be measured in the field unless otherwise indicated in these special provisions, or there is a significant change approved by the Engineer.

BID ITEM 10911 - MOBILIZATION

DESCRIPTION

Work under this item shall include all costs associated with mobilization of the Contractor to the site. Parking of equipment, storage of materials, and staging shall be allowed within project limits as shown on plans. The Contractor may only enter the construction site through the construction entrance as shown on the plans. THE CONTRACTOR MAY NOT DRIVE OR STORE EQUIPMENT ON ANY PORTION OF THE PARK OUTSIDE THE CONSTRUCTION LIMITS UNLESS INDICATED OTHERWISE ON PLANS OR DIRECTED IN THE FIELD.

The Contractor is responsible for restoration of any damage to the site due to construction access.

METHOD OF MEASUREMENT

Mobilization shall be paid as a lump sum for mobilization related to each project site.

BASIS OF PAYMENT

Mobilization shall be measured as described above and shall be paid for at the contract price which shall be full compensation for all work, materials, tools, equipment, labor, and incidentals required to complete the work as set forth in the description.

BID ITEM 20101 – EXCAVATION CUT

DESCRIPTION

Work under this item shall include loosening, loading, hauling and disposal of all materials. Excavation cut shall be in accordance with Article 201 of the Standard Specifications.

The excavation quantities for this contract have been calculated by subtracting digital terrain models of the existing and proposed surfaces and sub surfaces within the different material areas. Cut (in place quantities) and fill have been estimated from these models. No shrinkage factor has been applied to fill quantities to estimate net volume. The Contractor shall be responsible to review attached earthwork calculations. Three-dimensional Microstation (.dgn) files containing the digital terrain models used for the earthwork calculations are available.

The fill quantities for this contract have been computed by Microstation InRoads surface data volume. Adjustments were made for topsoil assuming excavation of six (6) inches of existing topsoil.

Excess excavated material deemed unusable shall be disposed of at a suitable location determined by the Contractor at no additional cost to the City of Madison.

Suitable materials (to be determined by the Engineer) may be reused as fill within the project limits. Placement of these fill materials shall be considered incidental to this bid item and shall not be compensated separately. All double handling and subsoil placement is included in this bid item.

It is anticipated that 1.8 cubic yards of subsoil shall be made available through Excavation Cut and 37.5 cubic yards of subsoil shall be distributed on-site through this bid item. Additional imported subsoil shall be paid under Bid Item 20202 Fill Borrow.

It is anticipated that 25.4 cubic yards of topsoil shall be made available through Excavation Cut and 17.8 cubic yards of topsoil shall be distributed on-site. Distribution of topsoil shall be paid under Bid Item 20221 Topsoil.

Contractor to note all excavated areas shall be filled at the end of each work day. No excavated areas shall be "open" during non-work hours.

METHOD OF MEASUREMENT

Excavation Cut shall be measured by the cubic yard quantity as listed in the proposal page without measurement thereof.

BASIS OF PAYMENT

Excavation Cut shall be measured as described above and shall be paid for at the contract unit price which shall be full compensation for all work, materials, labor, tools, equipment, disposal, and incidentals required to complete the work as set forth in the description

BID ITEM 20202 – FILL BORROW

DESCRIPTION

This item shall include all necessary work, labor and incidentals required to import and distribute fill to meet proposed subgrades. Fill shall comply with material described in Article 202 of the Standard Specifications.

The fill quantities for this contract have been computed by Microstation InRoads surface data volume. Adjustments were made for topsoil assuming excavation of six (6) inches of existing topsoil.

Within the project limits, an existing 2-foot cap of topsoil and clean fill covers the entire site. Beneath this clean cap there are isolated zones of petroleum-contaminated soils at the west end of the site, and the rest of the site is assumed to be contaminated with industrial fill.

As the proposed grades do not exceed the depth of the existing cap, it is anticipated the Contractor will not encounter contaminated soils. If the Contractor suspects contaminated soils are present during earthwork operations, the Contractor shall halt work and contact the project Engineer for further direction.

Double handling, stockpiling and placing fill is included in this bid item.

METHOD OF MEASUREMENT

Fill shall be measured by the cubic yard quantity as listed in the proposal page without measurement thereof.

BASIS OF PAYMENT

Fill shall be measured as described above and shall be paid for at the contract unit price which shall be full compensation for all work, materials, labor, tools, equipment, disposal, and incidentals required to complete the work as set forth in the description.

BID ITEM 20217 – CLEAR STONE

DESCRIPTION

This item shall include the quantity of clear stone required for the construction entrance per BID ITEM 21011 – CONSTRUCTION ENTRANCE.

METHOD OF MEASUREMENT

Clear Stone shall be measured by the ton as listed in the proposal page without measurement thereof.

BASIS OF PAYMENT

Clear Stone shall be measured as described above and shall be paid for at the contract unit price which shall be full compensation for all work, materials, labor, tools, equipment, disposal, and incidentals required to complete the work as set forth in the description.

BID ITEM 20221 - TOPSOIL

DESCRIPTION

This item shall include all necessary work, labor and incidentals required to distribute, dispose and/or place topsoil to meet proposed grades. Topsoil shall comply with Article 202 of the Standard Specifications.

Stripped topsoil can be stockpiled on site within the construction fence boundary.

The topsoil quantities for this contract have been computed by Microstation InRoads surface data volume computations and the assumptions listed above. Adjustments were made for topsoil assuming excavation of six (6) inches of existing topsoil.

Excess topsoil shall be disposed offsite at a location to be determined and provided by the City at no extra cost to the City or shall be used as import. The location shall be within the City of Madison. Double handling, stockpiling and placing topsoil is included in this bid item.

Contractor to note - the City of Madison Parks Construction Inspector is to be called to inspect and approve the finish grade prior to seeding and mulching.

METHOD OF MEASUREMENT

Topsoil shall be measured by the square yard quantity as listed in the proposal page without measurement thereof.

BASIS OF PAYMENT

Topsoil shall be measured as described above and shall be paid for at the contract unit price which shall be full compensation for all work, materials, labor, tools, equipment, disposal, and incidentals required to complete the work as set forth in the description.

BID ITEM 20701 – TERRACE SEEDING

DESCRIPTION

This work shall consist of preparing seed beds, furnishing and sowing the required seed, furnishing and applying the required stabilizers, fertilizer, and mulching material on all disturbed areas including areas damaged by construction activities, in accordance with Article 207 of the Standard Specifications. Seed mixture shall be either in whole, or a mixture of the City of Madison sun terrace mix and shade terrace mix applied appropriately based on shady and sunny areas of the site.

Since construction is limited to within the area contained by construction fence, no additional compensation shall be given for seeding quantities beyond what is specified in this contract.

Contractor to note – the City of Madison Parks Construction Inspector shall be called to inspect and approve the finish grade prior to seeding and mulching.

Contractor is responsible for obtaining seed bed germination per Article 207 of the Standard Specifications, regardless of site conditions.

METHOD OF MEASUREMENT

Terrace Seeding shall be measured by the square yard quantity as listed in the proposal page without measurement thereof.

BASIS OF PAYMENT

Terrace Seeding shall be measured as described above and shall be paid for at the contract unit price which shall be full compensation for all work, materials, tools, equipment, labor, hauling, placement, and incidentals required to complete the work as set forth in the description.

BID ITEM 21017 - SILT SOCK (8 INCH) - COMPLETE

DESCRIPTION

Work under this item shall include all work, materials, labor, and incidentals required to install, maintain and remove silt sock at locations shown on the plans and around any subsoil/topsoil staging piles and to install, maintain and remove additional undistributed silt sock as a precautionary measure to address emergency erosion control.

150 linear feet have been added to the proposal page for undistributed silt sock to be used around soil stockpiles. The quantity of this item may be reduced, increased, or eliminated based as needed for emergency sediment control and perimeter control around soil stockpiles.

METHOD OF MEASUREMENT

Silt Sock (8 inch) – Complete, shall be measured by linear foot for the completed work as described above.

BASIS OF PAYMENT

Silt Sock (8 inch) – Complete, shall be measured as described above and shall be paid for at the contract unit price which shall be full compensation for all work, materials, tools, equipment, labor, hauling, placement, disposal and incidentals required to complete the work as set forth in the description.

BID ITEM 21061 - EROSION MATTING, CLASS I URBAN TYPE A

DESCRIPTION

Work under this item shall include all work, materials, labor and incidentals necessary to install Erosion Matting, Class I Urban Type A on all seeded disturbed areas as noted in the plans.

The Class and Type requirements match those of the Wisconsin Department of Transportation Product Acceptability List (PAL) nomenclature. Products listed in the PAL as Class I Urban Type A are all 100 percent biodegradable, and therefore do not need to be designated ORGANIC.

Work under this bid item shall be as set forth in the latest edition of the Standard Specifications, except the Contractor shall note that special care with anchorage devices shall be required so as to not injure park users. Anchorage devices for the mat are required to be a product identified on the Wisconsin Department of Transportation Erosion Control Product Acceptability List (PAL) under the category of "Anchoring Devices for Class I, Urban Erosion Mat."

Anchorage devices shall be completely biodegradable. Photobiodegradable or metal anchorage devices shall not be allowed. Materials deemed to present a hazard from splintering or spearing shall not be approved, including solid wood devices.

Erosion Matting, Class I Urban Type A shall be installed correctly with correct anchorage, staple pattern, and overlap. To verify the staple pattern, the Contractor shall provide to the Engineer a manufacturer's recommended staple pattern for the type of matting installed.

Trimming of the Erosion Matting, Class I Urban Type A required to accommodate existing tree locations shall be considered incidental to this bid item.

METHOD OF MEASUREMENT

Erosion Matting, Class I Urban Type A shall be measured by the square yard quantity as listed in the proposal page without measurement thereof, not including run out and overlap.

BASIS OF PAYMENT

Erosion Matting, Class I Urban Type A shall be measured as described above and shall be paid for at the contract unit price which shall be full compensation for all work, materials, tools, equipment, labor, hauling, placement, disposal and incidentals required to complete the work as set forth in the description.

BID ITEM 40102 – CRUSHED AGGREGATE BASE COURSE GRADATION NO. 2

DESCRIPTION

Work under this bid item shall include all work, materials, labor and incidentals necessary for the Contractor to install 6 inches of Crushed Aggregate Base Course Gradation No. 2 for the thickened edge concrete slab.

All aggregate base course shall extend 6 inches beyond the proposed pavement edge and shall have 3 inches of topsoil and terrace seed over the extended gravel base to be paid for under BID ITEM 20221 – TOPSOIL and 20701 – TERRACE SEEDING.

The Contractor shall contact Dan Rodman at 658-3087 at least 48 hours prior to proof subgrade elevations prior to paving.

METHOD OF MEASUREMENT

Crushed Aggregate Base Course Gradation No. 2 shall be measured by the ton as listed in the proposal page without measurement thereof.

BASIS OF PAYMENT

Crushed Aggregate Base Course Gradation No. 2 shall be measured as described above and shall be paid for at the contract unit price which shall be full compensation for all work, materials, tools, equipment, labor, hauling, placement, disposal and incidentals required to complete the work as set forth in the description.

BID ITEM 90000 - CONSTRUCTION FENCING (PLASTIC)

DESCRIPTION

Work under this item shall include all work, materials, labor and incidentals necessary for the Contractor to provide, install, maintain and remove construction fence from the project site as shown on the plans.

Construction fencing shall be installed to discourage access to the construction area by the general public during the course of the project. Fencing shall be maintained throughout construction and adjusted or removed at the request of the Engineer.

This fence shall be highly visible (orange), constructed of a plastic web, and able to withstand the expected amount of use it shall receive on a construction site. Relocation of fencing may be required as the work progresses. No extra payment shall be made for temporarily opening and re-closing the fence, or relocation of the fencing as needed to perform the work. Fencing shall be left in place until construction operations are complete.

Construction fencing shall be International Orange color, high-density polyethylene mesh conforming to the following:

- Mesh opening: 1 inch minimum to 3 inch maximum
- Height: 4 feet
- Ultimate tensile strength: Avg 3000 lb per 4' width (ASTM D638)

Construction fencing associated with tree protection is incidental to this bid item.

METHOD OF MEASUREMENT

Construction Fence (Plastic) shall be measured by the linear foot quantity as listed in the proposal page without measurement thereof.

BASIS OF PAYMENT

Construction Fence (Plastic) shall be measured as described above and shall be paid for at the contract unit price which shall be full compensation for all work, materials, tools, equipment, labor, hauling, placement, disposal and incidentals required to complete the work as set forth in the description.

BID ITEM 90001 – THICKENED EDGE CONCRETE SLAB

DESCRIPTION

Work under this item shall include all work, materials, labor and incidentals necessary for the Contractor to install the thickened edge concrete slab including forming, reinforcing and finishing in accordance with the plans, details and testing and material standards established in Article 303 of the City of Madison Standard Specifications for Public Works Construction. Crushed aggregate base course shall be paid separately under BID ITEM 40102 – CRUSHED AGGREGATE BASE COURSE, GRADATION NO. 2. Concrete wash-out area shall be considered incidental to this bid item.

The following items are incidental to this bid item:

- #4 Epoxy coated rebar
- 6"x6" woven wire mesh (WWM)
- Control joints as indicated on plans and details
- Broom finish as indicated on plans and details

METHOD OF MEASUREMENT

Thickened Edge Concrete Slab shall be measured per lump sum as listed in the proposal page without measurement thereof.

BASIS OF PAYMENT

Thickened Edge Concrete Slab shall be measured as described above and shall be paid for at the contract unit price which shall be full compensation for all work, materials, tools, equipment, labor, hauling, placement, disposal and incidentals required to complete the work as set forth in the description.

BID ITEM 90002 – REMOVE AND RE-INSTALL EXISTING FENCE

DESCRIPTION

Work under this item shall include all work, materials, labor and incidentals necessary for the Contractor to remove and re-install sections of the existing skatepark fence including approximately 19 linear feet at the western edge of the project area for construction vehicle access and approximately 42 linear feet at the northern edge of the project area to minimize conflicts with the fence during placement and positioning of the boulder retaining wall.

METHOD OF MEASUREMENT

Remove and Re-Install Existing Fence shall be measured per linear foot as listed in the proposal page.

BASIS OF PAYMENT

Remove and Re-Install Existing Fence shall be measured as described above and shall be paid for at the contract unit price which shall be full compensation for all work, materials, tools, equipment, labor, hauling, placement, disposal and incidentals required to complete the work as set forth in the description.

BID ITEM 90003 – ORNAMENTAL METAL FENCE

DESCRIPTION

Work includes all labor, materials and equipment necessary to fabricate and install decorative metal picket fencing per details and as shown on the plans, Sheet 1.5. All fittings, fasteners, concrete footings, and miscellaneous related items shall be incidental to this item.

Submit shop drawings to the City of Madison for review, including location of fence, posts, rails, details, hardware, and accessories. Indicate materials, dimensions, sizes, and finishes of components. Verify layout information for fences shown on Drawings in relation to property survey, existing utilities, and field measurements.

Structural tubing shall conform to ASTM A500 Grade B.

Steel plates shall conform to ASTM A 36/A 36M.

Posts shall be vertical. Post base plates shall be flat withal surfaces smooth and free from warp and all edges smooth, straight and vertical. Safety posts shall have maximum openings of less than 4".

Fabricate Ornamental Metal Fence by welding. Cope components at perpendicular and skew connections to provide close fit, or use fittings designed for this purpose. Weld connections continuously to comply with the following:

1. Use materials and methods that minimize distortion and develop strength and corrosion resistance of base metals.
2. Obtain fusion without undercut or overlap.
3. Remove flux immediately.
4. At exposed connections, finish exposed surfaces smooth and blended so no roughness shows after finishing and welded surface matches contours of adjoining surfaces.
5. Provide weep holes or another means to drain entrapped water in hollow sections of fence members that are exposed to exterior or to moisture from condensation or other sources.

Railing shall be fabricated in lengths to minimize field splicing.

Touch-up painting to be done at completion of Ornamental Metal Fence installation to the satisfaction of the Engineer.

METHOD OF MEASUREMENT

Ornamental Metal Fence shall be measured per linear foot as listed in the proposal page without measurement thereof.

BASIS OF PAYMENT

Ornamental Metal Fence shall be as described above and shall be paid for at the contract unit price which shall be full compensation for all work, materials, tools, equipment, labor, hauling, placement, disposal and incidentals required to complete the work as set forth in the description.

BID ITEM 90004 – INSTALL BOULDER RETAINING WALL

DESCRIPTION

Work under this item shall include all work, materials, labor and incidentals necessary for the Contractor to install a boulder retaining wall in accordance with these plans and specifications. The boulders shall be glacially tumbled, natural fieldstone of approximately 36"x36"x36". The boulders shall not have significant sharp or jagged edges and shall be free of mud and debris. Crushed stone base, clear stone backfill, drain tile and geotextile fabric are incidental to this bid item.

The following items are incidental to this bid item:

- Fieldstone boulders
- Crushed stone base
- Geotextile fabric
- 4" Perforated drain tile
- ¾" Clear stone

METHOD OF MEASUREMENT

Install Boulder Retaining Wall shall be measured per lump sum for the acceptably completed work as described above.

BASIS OF PAYMENT

Install Boulder Retaining Wall shall be measured as described above and shall be paid at the contract price which shall be full compensation for all work, materials, tools, equipment, labor, hauling, placement, disposal and incidentals required to complete the work as set forth in the description.

BID ITEM 90005 – INSTALL PREFABRICATED BLEACHER

DESCRIPTION

Work under this item shall include all labor, materials and incidentals necessary for the Contractor to assemble and install National Recreation Systems 3 Row bleacher (Model #NB-0327 ADLX), surface mounted, as shown on plan Sheet 1.5 and the manufacturer's installation instructions (Attachment A). All fittings, fasteners, and miscellaneous related to surface-mount installation shall be incidental to this item.

The bleacher **will be purchased by the City of Madison** and ordered for delivery from vendor to City of Madison Parks Division Goodman Maintenance Facility, 1402 Wingra Creek Parkway, Madison WI 53715. The Contractor shall be responsible for contacting Andy Peters (608) 220-6501 to arrange pick-up and for loading and delivery of the bleacher from this location to the project site.

METHOD OF MEASUREMENT

Install Prefabricated Bleacher shall be measured per lump sum for the acceptably completed work as described above.

BASIS OF PAYMENT

Install Prefabricated Bleacher shall be measured as described above and shall be paid at the contract price which shall be full compensation for all work, materials, tools, equipment, labor, hauling, placement, disposal and incidentals required to complete the work as set forth in the description.

END OF SPECIAL PROVISIONS



Madison Parks Division

210 Martin Luther King, Jr. Blvd., Room 104
PO Box 2987
Madison, WI 53701-2987
608-266-4711 • cityofmadison.com/parks



September 17, 2018

NOTICE OF ADDENDUM ADDENDUM 1 CONTRACT NO. 8273

Revise and amend the contract document(s) for the above project as stated in this addendum, otherwise, the original document shall remain in effect.

Please acknowledge this addendum on page E1 of the contract documents and/or in Section E: Bidder's Acknowledgement on Bid Express.

Electronic version of these documents can be found on the Bid Express web site at:

<http://www.bidexpress.com>

This Addendum consists of **1 page** and these attached documents.

CHANGES TO BIDDING REQUIREMENTS:

NONE

CHANGES TO CONDITIONS OF THE CONTRACT:

NONE

CHANGES TO SPECIFICATIONS:

NONE

CHANGES TO DRAWINGS:

1. ADD - Attached construction drawings, 1.1-1.6

If you are unable to download plan revisions associated with the addendum, please contact the Engineering office at 608-266-4751 receive the material by another route.

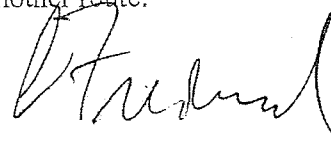
 (For Eric Knepp)

Eric Knepp, Parks Superintendent

9/17/18

END OF ADDENDUM

McPIKE PARK - SKATEPARK SEATING AREA CONTRACT 8273

McPIKE PARK - MUNIS # 10524 -51 -130

McPIKE PARK
202 S. INGERSOLL

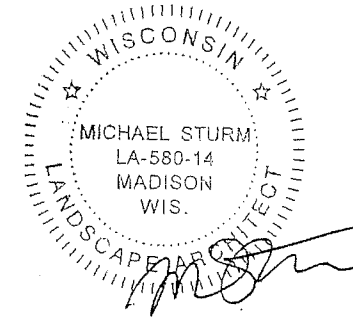
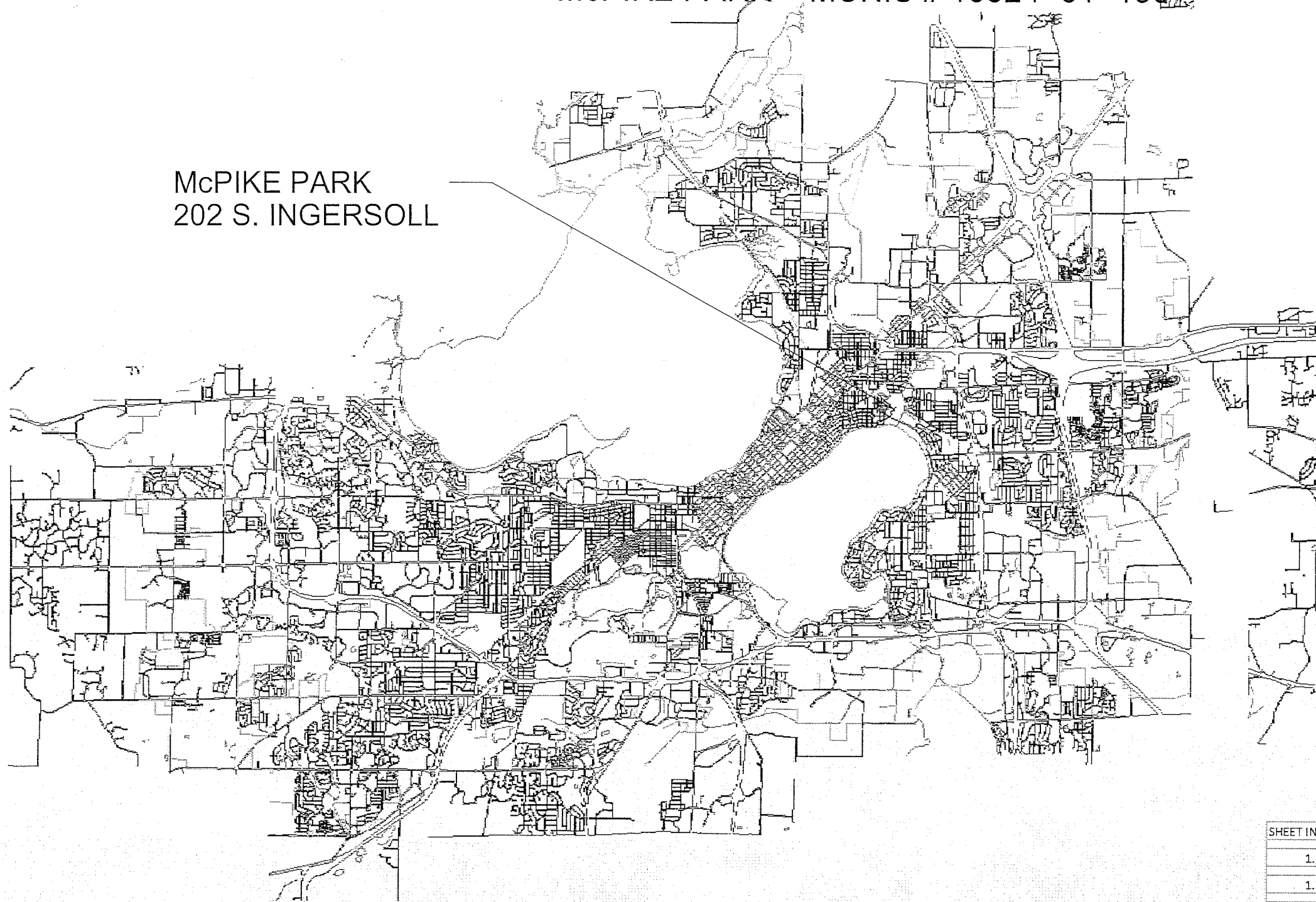

City of Madison
Department of Public Works
PARKS DIVISION
City-County Building, Suite 104
210 Martin Luther King, Jr. Blvd.
Madison, WI 53703

play
**MADISON
PARKS**

PROJECT:
*McPIKE PARK
SKATEPARK
SEATING AREA*

*McPIKE PARK
202 S INGERSOLL
MADISON, WI 53703*

Although every effort has been made in preparing these plans and checking them for accuracy, the contractor and subcontractors must check all details and dimensions of their trade and be responsible for the same.

ITEM	DATE
Drawn by: MS/KK	06-29-2018

PUBLIC WORKS PROJECT #:
8273

SHEET TITLE:

SHEET NUMBER:

SHEET INDEX:	
1.1	PROJECT LOCATION AND SITE ACCESS PLAN
1.2	DEMOLITION AND PROTECTION PLAN
1.3	SITE PLAN
1.4	GRADING AND EROSION CONTROL PLAN
1.5	SITE SECTION AND DETAILS
1.6	EARTHWORK COMPUTATIONS

City of Madison
 Department of Public Works
PARKS DIVISION
 City-County Building, Suite 104
 210 Martin Luther King, Jr. Blvd.
 Madison, WI 53703

play
**MADISON
 PARKS**

Graphical Scale
 0 60 ft



PROJECT:
**McPIKE PARK
 SKATEPARK
 SEATING AREA**

**McPIKE PARK
 202 S INGERSOLL
 MADISON, WI 53703**

Although every effort has been made in preparing these plans and checking them for accuracy, the contractor and subcontractors must check all details and dimensions of their trade and be responsible for the same.

ITEM	DATE
Drawn by: MS/KK	06-29-2018

PUBLIC WORKS PROJECT #:
8273

SHEET TITLE:
**PROJECT LOCATION
 AND SITE ACCESS**

SHEET NUMBER:
1.1

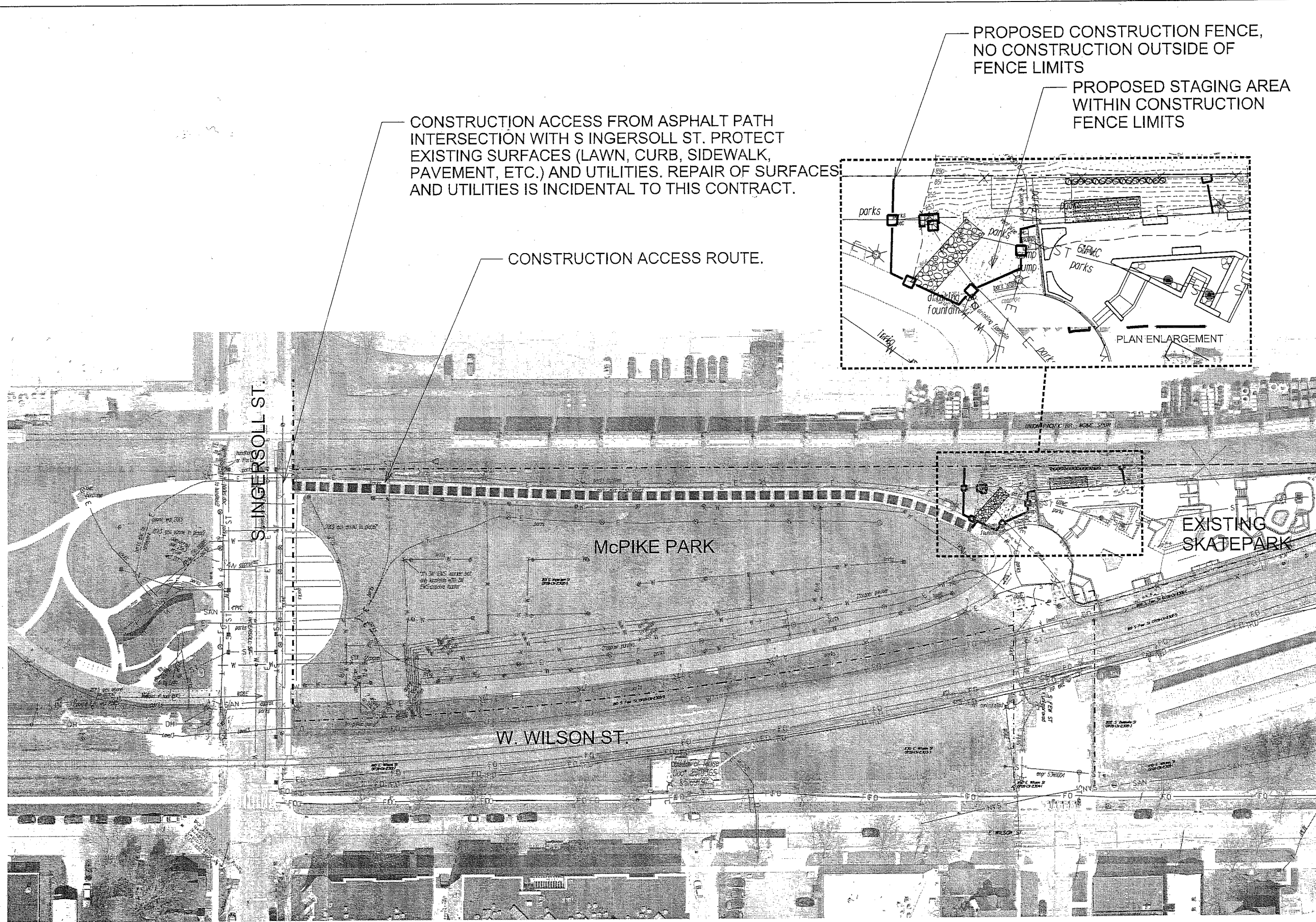

CONSTRUCTION ACCESS FROM ASPHALT PATH INTERSECTION WITH S INGERSOLL ST. PROTECT EXISTING SURFACES (LAWN, CURB, SIDEWALK, PAVEMENT, ETC.) AND UTILITIES. REPAIR OF SURFACES AND UTILITIES IS INCIDENTAL TO THIS CONTRACT.

CONSTRUCTION ACCESS ROUTE.

PROPOSED CONSTRUCTION FENCE, NO CONSTRUCTION OUTSIDE OF FENCE LIMITS

PROPOSED STAGING AREA WITHIN CONSTRUCTION FENCE LIMITS

PLAN ENLARGEMENT







EXISTING SKATEPARK

McPIKE PARK

W. WILSON ST.

S INGERSOLL ST.

LEGEND

-  REMOVE EX. LAWN
-  PRO. CONSTRUCTION ENTRANCE
-  PRO. CONSTRUCTION FENCE
-  PRO. SILT SOCK
-  EX. SKATEPARK FENCE
-  EX. CONTOUR (INDEX)
-  EX. CONTOUR (INTER.)
-  EX. PROPERTY LINE

NOTES

1.) THE CONTRACTOR IS RESPONSIBLE FOR REPAIRING ANY EXISTING UTILITIES, STRUCTURES, SIDEWALK, CURB, LAWN, PAVEMENT, ETC. DAMAGED THROUGH CONSTRUCTION ACTIVITIES AT THEIR OWN EXPENSE. REPAIRS MUST BE MADE IN ACCORDANCE WITH THE CITY OF MADISON STANDARD SPECIFICATIONS FOR PUBLIC WORKS CONSTRUCTION.

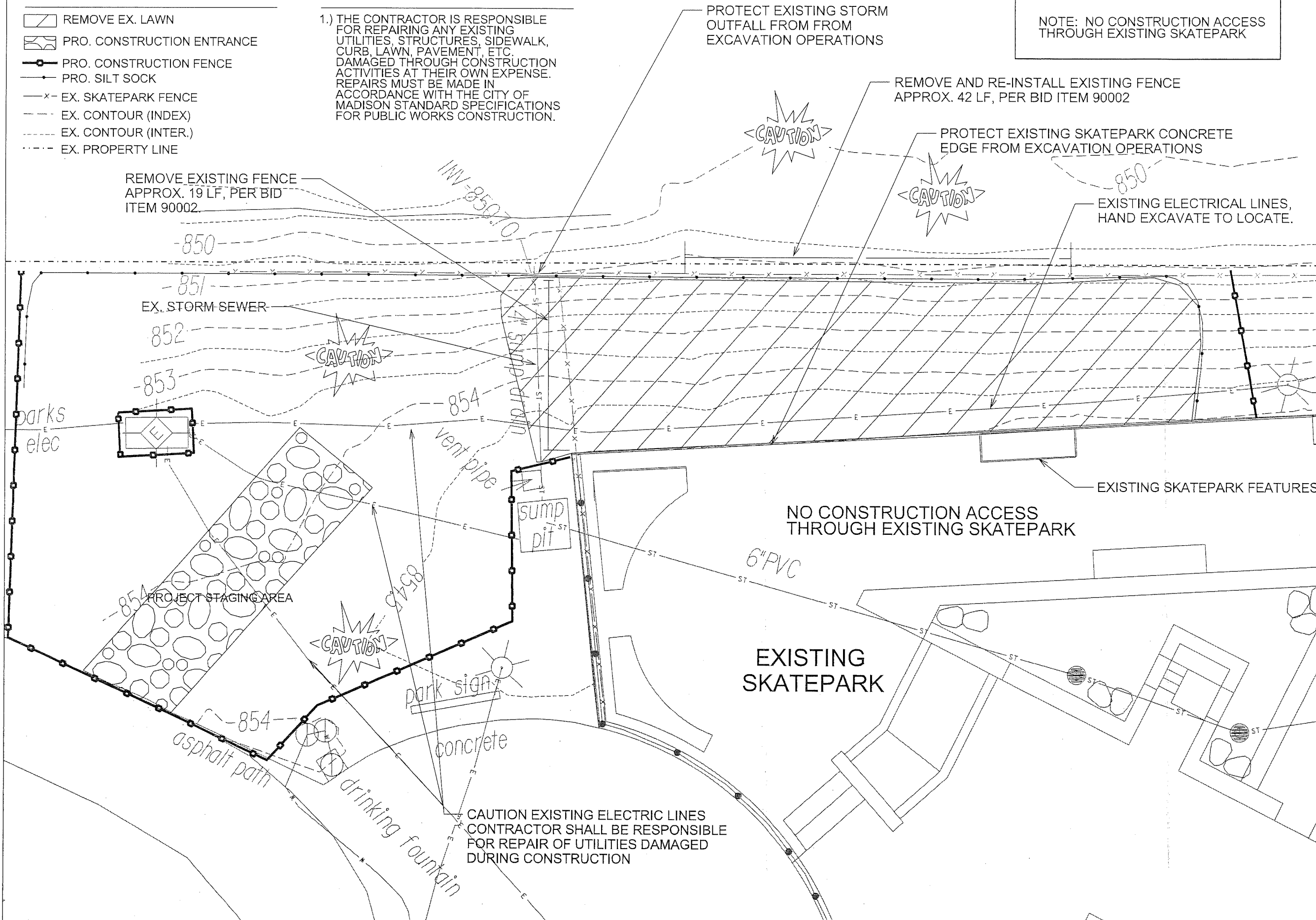

City of Madison
 Department of Public Works
PARKS DIVISION
 City-County Building, Suite 104
 210 Martin Luther King, Jr. Blvd.
 Madison, WI 53703

play
MADISON PARKS

Graphical Scale
 0 10 ft N

PROJECT:
**McPIKE PARK
 SKATEPARK
 SEATING AREA**

**McPIKE PARK
 202 S INGERSOLL
 MADISON, WI 53703**

Although every effort has been made in preparing these plans and checking them for accuracy, the contractor and subcontractors must check all details and dimensions of their trade and be responsible for the same.







ITEM	DATE
Drawn by: KK	06-29-2018

PUBLIC WORKS PROJECT #:
8273

SHEET TITLE:
**DEMOLITION AND
 PROTECTION PLAN**

SHEET NUMBER:
1.2

LEGEND

-  PROP. CONCRETE
-  PROP. CONTROL JOINT
-  PROP. ORNAMENTAL FENCE
-  EX. SKATEPARK FENCE
-  EX. CONTOUR (INDEX)
-  EX. CONTOUR (INTER)
-  EX. PROPERTY LINE

NOTES

1.) THE CONTRACTOR IS RESPONSIBLE FOR REPAIRING ANY EXISTING UTILITIES, STRUCTURES, SIDEWALK, CURB, LAWN, PAVEMENT, ETC. DAMAGED THROUGH CONSTRUCTION ACTIVITIES AT THEIR OWN EXPENSE. REPAIRS MUST BE MADE IN ACCORDANCE WITH THE CITY OF MADISON STANDARD SPECIFICATIONS FOR PUBLIC WORKS CONSTRUCTION.

NOTE: NO CONSTRUCTION ACCESS THROUGH EXISTING SKATEPARK

City of Madison
 Department of Public Works
PARKS DIVISION
 City-County Building, Suite 104
 210 Martin Luther King, Jr. Blvd.
 Madison, WI 53703

play
MADISON
PARKS

Graphical Scale
 0 10 ft



PROJECT:

McPIKE PARK
 SKATEPARK
 SEATING AREA

McPIKE PARK
 202 S INGERSOLL
 MADISON, WI 53703

Although every effort has been made in preparing these plans and checking them for accuracy, the contractor and subcontractors must check all details and dimensions of their trade and be responsible for the same.

ITEM	DATE
Drawn by: KK	06-29-2018







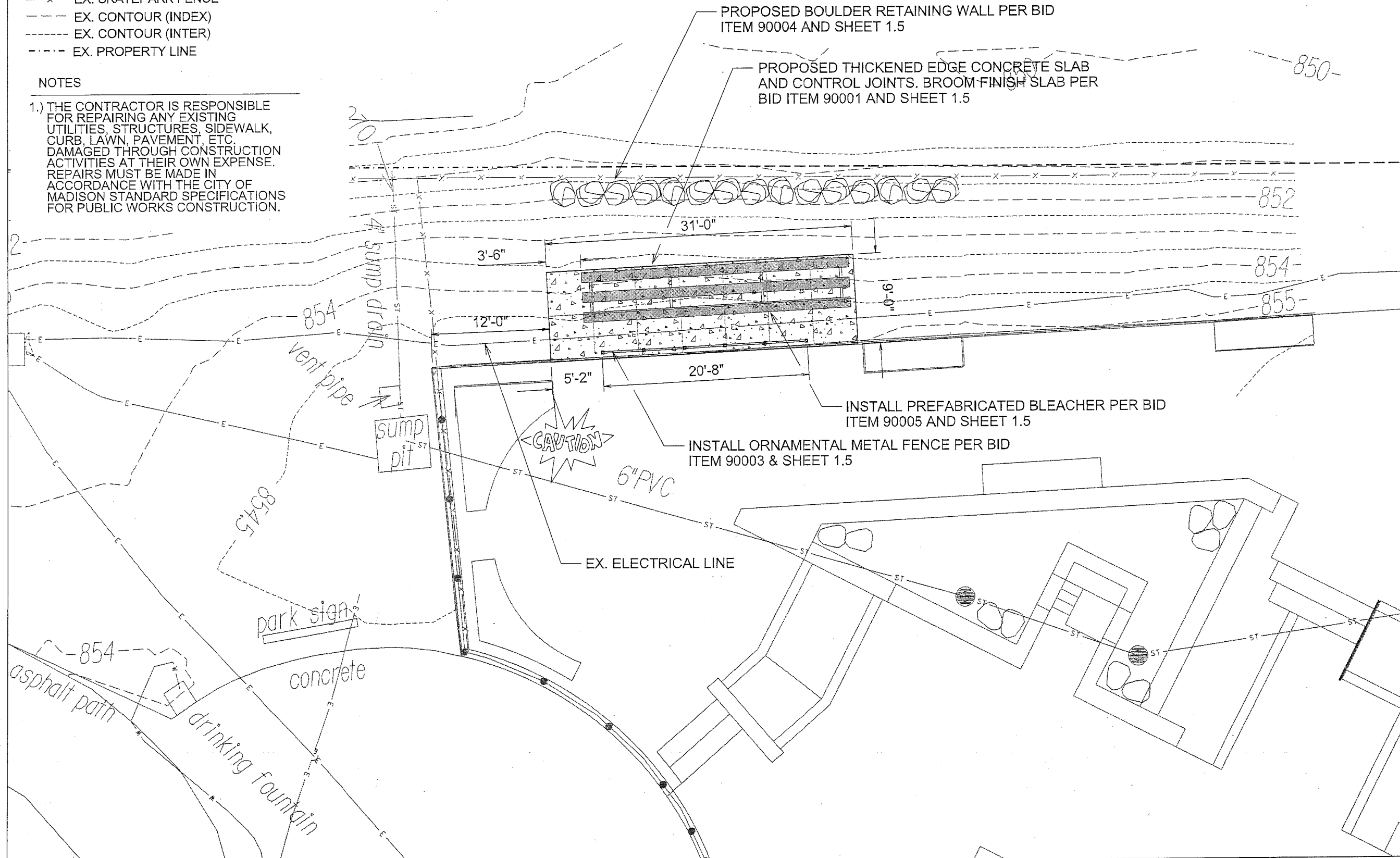





PUBLIC WORKS PROJECT #:
8273

SHEET TITLE:
SITE PLAN

SHEET NUMBER:
1.3



LEGEND

-  PRO. SPOT EL.
-  PRO. SLOPE
-  PRO. EROSION MATTING
-  PRO. CONSTRUCTION ENTRANCE
-  PRO. GRADING LIMITS
-  PRO. CONSTRUCTION FENCE
-  PRO. SILT SOCK
-  PRO. CONTOUR (INDEX)
-  PRO. CONTOUR (INTER)
-  EX. CONTOUR (INDEX)
-  EX. CONTOUR (INTER.)
-  EX. SKATEPARK FENCE
-  EX. PROPERTY LINE

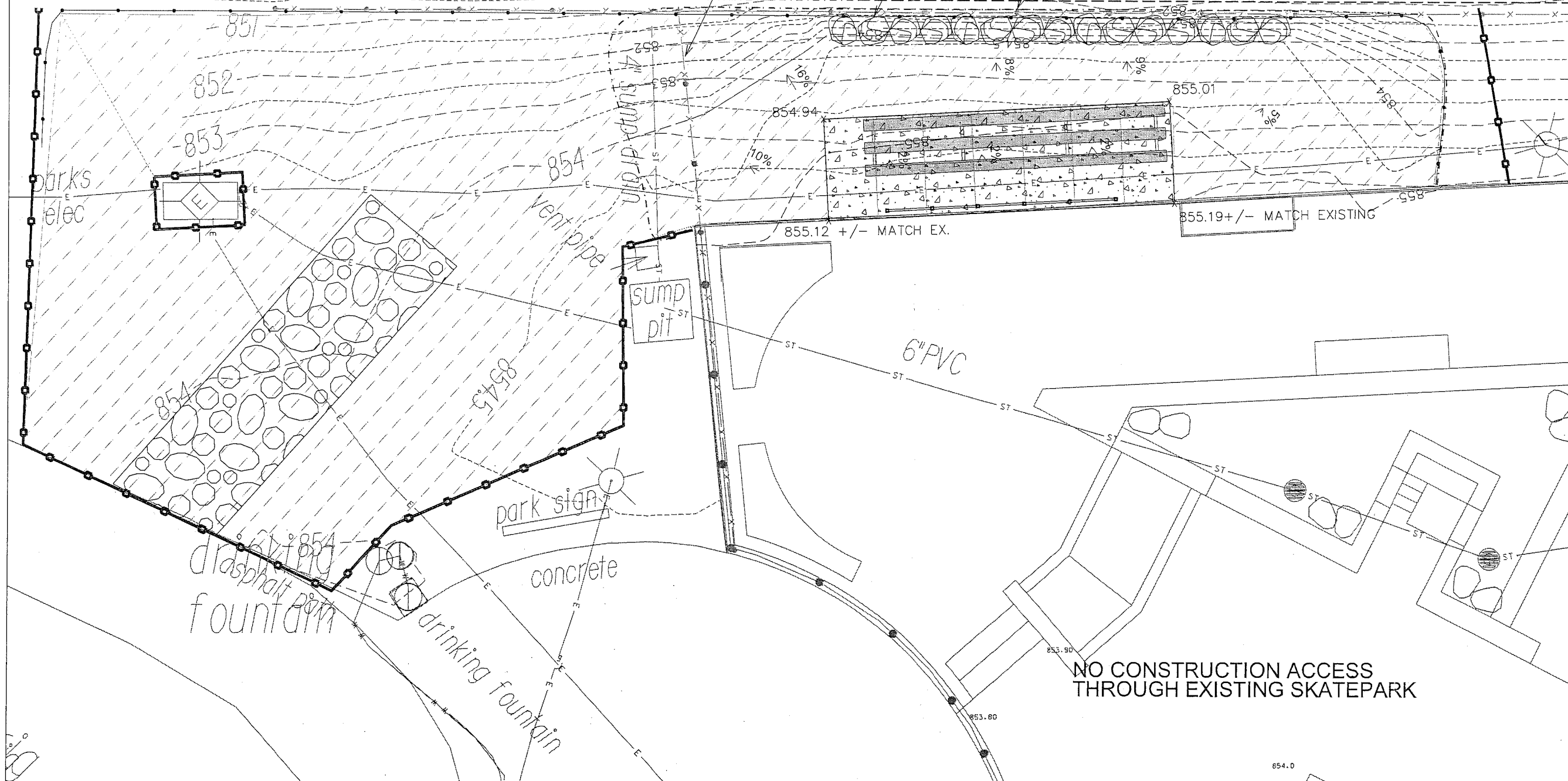

City of Madison
 Department of Public Works
PARKS DIVISION
 City-County Building, Suite 104
 210 Martin Luther King, Jr. Blvd.
 Madison, WI 53703

play
**MADISON
 PARKS**

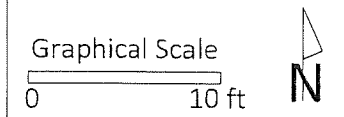

PROJECT:
**McPIKE PARK
 SKATEPARK
 SEATING AREA**

**McPIKE PARK
 202 S INGERSOLL
 MADISON, WI 53703**

Although every effort has been made in preparing these plans and checking them for accuracy, the contractor and subcontractors must check all details and dimensions of their trade and be responsible for the same.

ITEM	DATE
Drawn by: IMS/KK	06-29-2018

PUBLIC WORKS PROJECT #:
8273

SHEET TITLE:
**GRADING AND
 EROSION
 CONTROL PLAN**

SHEET NUMBER:
1.4

McPike Park Skatepark Seating Area - Earthwork Quantities

City of Madison, WI Public Works Contract
 Date Revised: 7/12/2018

Notes:

Positive volumes are cuts, negative volumes are fills.
 Not all parts of all surface models (Digital Terrain Models) are used for computations or intended for actual construction.

Existing
 Proposed
 Proposed

Sort	Grp	Material	Item	From Surface Model	To Surface Model	area (sq ft)	depth (ft)	Unfac-tored volume (cu ft)	Unfac-tored volume (cu yd)	Expan-sion Factor (%)	Factored (Uncom-pacted) Volume (cu yd)
	Grass to Grass	Topsoil Excavate	Strip 6in topsoil	n/a	n/a	962	0.50	481	17.8	0%	17.8
	Grass to Grass	Subsoil Excavate	Cut subsoil to proposed subgrade	Ex-6in	Pro-6in	962	varies	10	0.4	0%	0.4
	Grass to Grass	Subsoil Place	Fill subsoil to proposed subgrade	Ex-6in	Pro-6in	962	varies	-924	-34.2	0%	-34.2
	Grass to Grass	Topsoil Place	Place 6in topsoil	n/a	n/a	962	-0.50	-481	-17.8	0%	-17.8
	Grass to Concrete	Topsoil Excavate	Strip 6in topsoil	n/a	n/a	279	0.50	140	5.2	0%	5.2
	Grass to Concrete	Subsoil Excavate	Cut subsoil to proposed subgrade	Ex-6in	Pro-12in	279	varies	30	1.1	0%	1.1
	Grass to Concrete	Subsoil Place	Fill subsoil to proposed subgrade	Ex-6in	Pro-12in	279	varies	-60	-2.2	0%	-2.2
	Grass to Concrete	Gravel (for Pavement) Place	Place 6in gravel base	n/a	n/a	279	-0.50	-140	-5.2	0%	-5.2
	Grass to Concrete	Concrete Place	Place 6 in concrete	n/a	n/a	279	-0.50	-140	-5.2	0%	-5.2
	Grass to Boulder Base	Topsoil Excavate	Strip 6in topsoil	n/a	n/a	131	0.50	66	2.4	0%	2.4
	Grass to Boulder Base	Subsoil Excavate	Cut subsoil to proposed subgrade	Ex-6in	Elev 851.5	131	varies	9	0.3	0%	0.3

McPike Park Skatepark Seating Area - Earthwork Quantities

City of Madison, WI Public Works Contract
 Date Revised: 7/13/2018

Derived from more detailed spreadsheet available from Parks Division

Computation Summary

Positive volumes are cuts (material available), negative volumes are fills (material needed)

Row Labels	Sum of Unfac-tored volume (cu yd)
Gravel (for Pavement) Place	-5.2
Subsoil Excavate	1.8
Subsoil Place	-37.6
Topsoil Excavate	25.4
Topsoil Place	-17.8
Concrete Place	-5.2
Grand Total	-38.4

Reorganized into bid table items

Bid Item	Quantity	Units	Relation to Table Above
20101 Excavation Cut	27	CY	=Subsoil Excavate + Topsoil Excavate
20202 Fill Borrow	36	CY	= Subsoil Excavate - Subsoil Place
20221 Topsoil	-107	SY	= Topsoil Place/.5 (depth)
40102 Crushed Aggregate Base Course Gradation No. 2 & 3	10.3	TONS	= (Gravel Place) * 2.0 ton/cubic yard

City of Madison
 Department of Public Works
PARKS DIVISION
 City-County Building, Suite 104
 210 Martin Luther King, Jr. Blvd.
 Madison, WI 53703



PROJECT:

*McPIKE PARK
 SKATEPARK
 SEATING AREA*

*McPIKE PARK
 202 S INGERSOLL
 MADISON, WI 53703*

Although every effort has been made in preparing these plans and checking them for accuracy, the contractor and subcontractors must check all details and dimensions of their trade and be responsible for the same.

ITEM DATE
 Drawn by: MS 06-29-2018

PUBLIC WORKS PROJECT #:
8273

SHEET TITLE:
**EARTHWORK
 COMPUTATIONS**

SHEET NUMBER:
1.6

PROJECT:
*McPIKE PARK
 SKATEPARK
 SEATING AREA*

*McPIKE PARK
 202 S INGERSOLL
 MADISON, WI 53703*

Although every effort has been made in preparing these plans and checking them for accuracy, the contractor and subcontractors must check all details and dimensions of their trade and be responsible for the same.

ITEM DATE
 Drawn by: MS 06-29-2018

PUBLIC WORKS PROJECT #:
8273

SHEET TITLE:
**SITE SECTION
 AND DETAILS**

SHEET NUMBER:
1.5

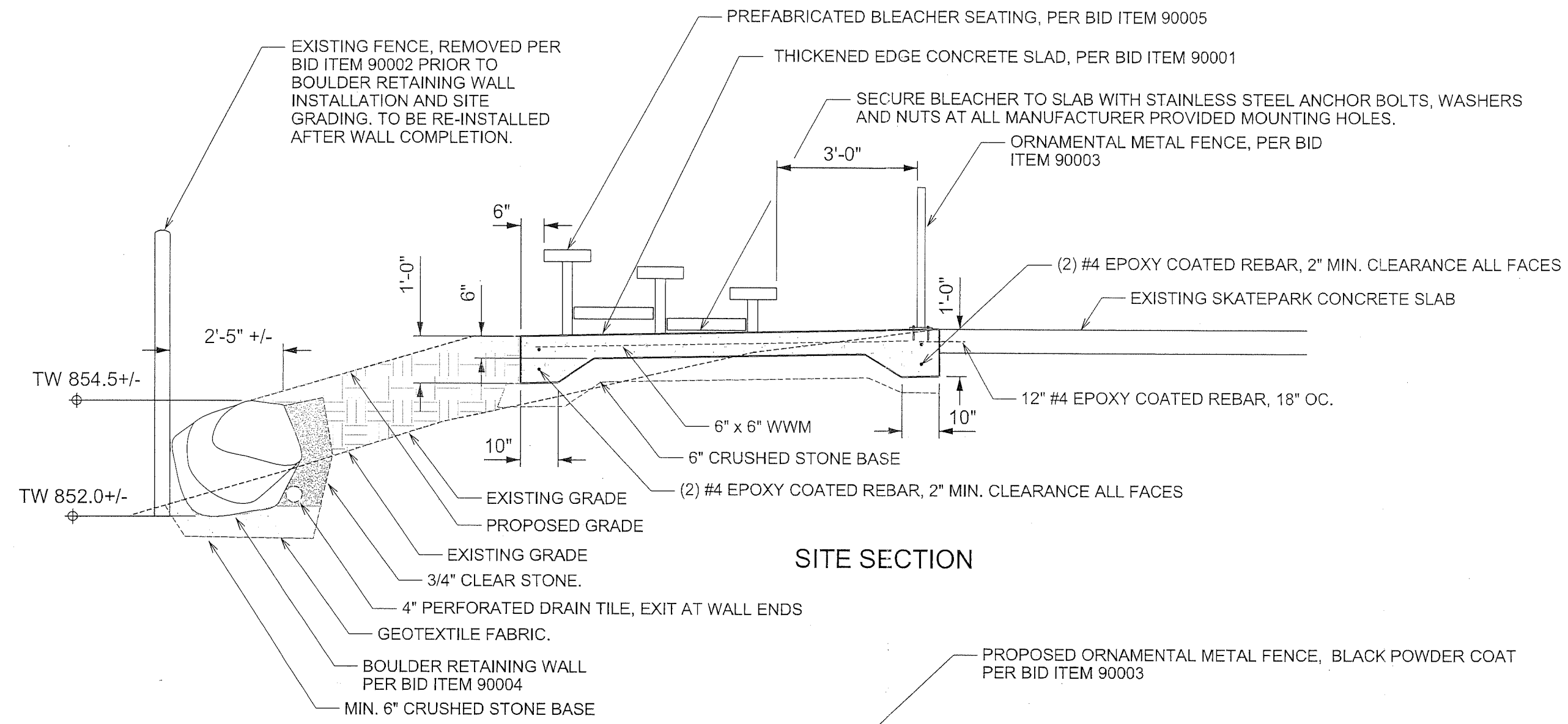

SITE SECTION

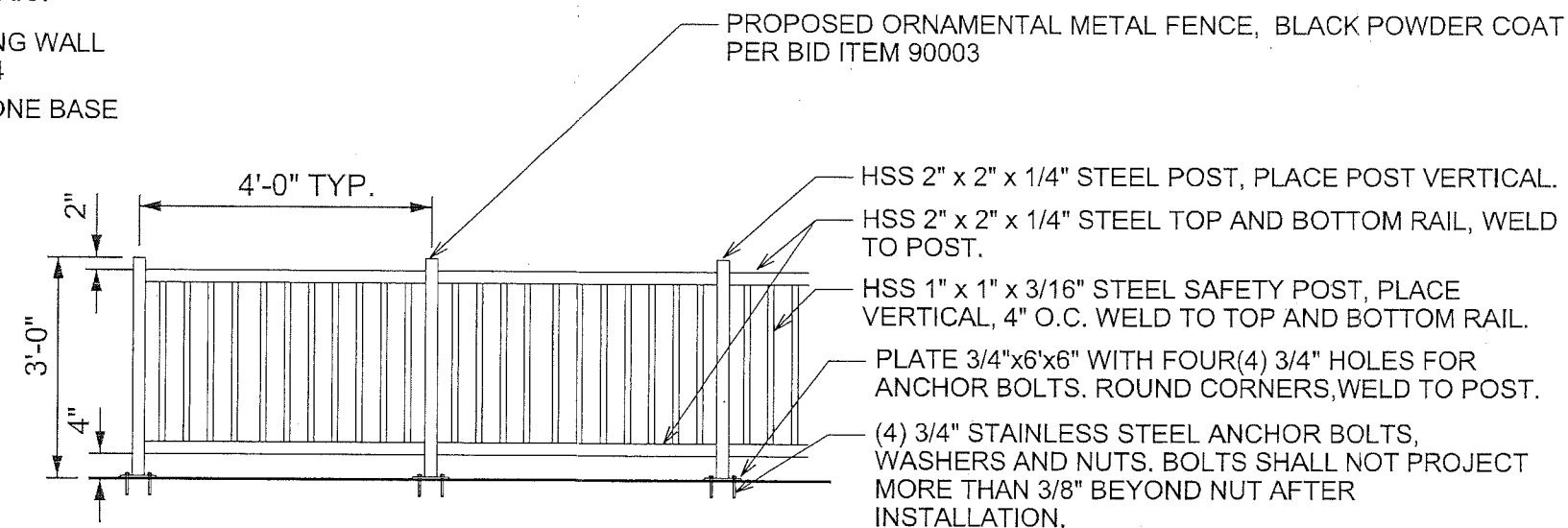

ORNAMENTAL METAL FENCE

NOTE: ALL JOINTS SHALL BE WELDED PER AWS D 1.5 (POSTS, TOP AND BOTTOM RAILS, SAFETY POSTS AND POST FLANGES).

SECTION E: BIDDERS ACKNOWLEDGEMENT

MCPIKE PARK - SKATEPARK SEATING AREA
CONTRACT NO. 8273

Bidder must state a Unit Price and Total Bid for each item. The Total Bid for each item must be the product of quantity, by Unit Price. The Grand Total must be the sum of the Total Bids for the various items. In case of multiplication errors or addition errors, the Grand Total with corrected multiplication and/or addition shall determine the Grand Total bid for each contract. The Unit Price and Total Bid must be entered numerically in the spaces provided. All words and numbers shall be written in ink.

- The undersigned having familiarized himself/herself with the Contract documents, including Advertisement for Bids, Instructions to Bidders, Form of Proposal, City of Madison Standard Specifications for Public Works Construction - 2018 Edition thereto, Form of Agreement, Form of Bond, and Addenda issued and attached to the plans and specifications on file in the office of the City Engineer, hereby proposes to provide and furnish all the labor, materials, tools, and expendable equipment necessary to perform and complete in a workmanlike manner the specified construction on this project for the City of Madison; all in accordance with the plans and specifications as prepared by the City Engineer, including Addenda Nos. 1 through _____ to the Contract, at the prices for said work as contained in this proposal. (Electronic bids submittals shall acknowledge addendum under Section E and shall not acknowledge here)
- If awarded the Contract, we will initiate action within seven (7) days after notification or in accordance with the date specified in the contract to begin work and will proceed with diligence to bring the project to full completion within the number of work days allowed in the Contract or by the calendar date stated in the Contract.
- The undersigned Bidder or Contractor certifies that he/she is not a party to any contract, combination in form of trust or otherwise, or conspiracy in restraint of trade or commerce or any other violation of the anti-trust laws of the State of Wisconsin or of the United States, with respect to this bid or contract or otherwise.
- I hereby certify that I have met the Bid Bond Requirements as specified in Section 102.5. (IF BID BOND IS USED, IT SHALL BE SUBMITTED ON THE FORMS PROVIDED BY THE CITY. FAILURE TO DO SO MAY RESULT IN REJECTION OF THE BID).
- I hereby certify that all statements herein are made on behalf of Raymond P. Cattell LLC (name of corporation, partnership, or person submitting bid) a corporation organized and existing under the laws of the State of WISCONSIN a partnership consisting of _____; an individual trading as _____ of the City of MADISON; State of _____; that I have examined and carefully prepared this Proposal; from the plans and specifications and have checked the same in detail before submitting this Proposal; that I have fully authority to make such statements and submit this Proposal in (its, their) behalf; and that the said statements are true and correct.

[Signature]
SIGNATURE

[Signature]
TITLE, IF ANY

Sworn and subscribed to before me this 20th day of SEPT., 2018.

(Notary Public or other officer authorized to administer oaths)
My Commission Expires 12/13/23

Bidders shall not add any conditions or qualifying statements to this Proposal.

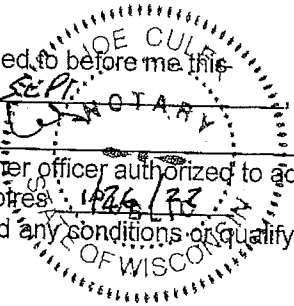

Contract 8273 – Raymond P. Cattell, Inc.

Section F: Best Value Contracting (BVC) Form

This section is a required document for the bid to be considered complete. There are two methods for completing the Best Value Contracting (BVC) form. Method one: The form can be filled out online and submitted to this site to be included with your electronic bid. Method two: The form can be downloaded from the site and submitted by hand to the City of Madison.

Method of Submittal of Best Value Contracting form (click in box below to choose) *

I will submit Bid Express fillable online form (BVC).

Best Value Contracting

1. The Contractor shall indicate the non-apprenticeable trades used on this contract.

2. Madison General Ordinance (M.G.O.), 33.07(7), does provide for some exemptions from the active apprentice requirement. Apprenticeable trades are those trades considered apprenticeable by the State of Wisconsin. Please check applicable box if you are seeking an exemption.

- Contractor has a total skilled workforce of four or less individuals in all apprenticeable trades combined.
- No available trade training program; The Contractor has been rejected by the only available trade training program, or there is no trade training program within 90 miles.
- Contractor is not using an apprentice due to having a journey worker on layoff status, provided the journey worker was employed by the contractor in the past six months.
- First time contractor on City of Madison Public Works contract requests a onetime exemption but intends to comply on all future contracts and is taking steps typical of a "good faith" effort.
- Contractor has been in business less than one year.
- Contractor doesn't have enough journeyman trade workers to qualify for a trade training program in that respective trade.

3. The Contractor shall indicate on the following section which apprenticeable trades are to be used on this contract. Compliance with active apprenticeship, to the extent required by M.G.O. 33.07(7), shall be satisfied by documentation from an applicable trade training body; an apprenticeship contract with the Wisconsin Department of Workforce Development or a similar agency in another state; or the U.S Department of Labor. This documentation is required prior to the Contractor beginning work on the project site.

The Contractor has reviewed the list and shall not use any apprenticeable trades on this project.

LIST APPRENTICABLE TRADES (check all that apply to your work to be performed on this contract)

- BRICKLAYER
- CARPENTER
- CEMENT MASON / CONCRETE FINISHER
- CEMENT MASON (HEAVY HIGHWAY)
- CONSTRUCTION CRAFT LABORER
- DATA COMMUNICATION INSTALLER
- ELECTRICIAN
- ENVIRONMENTAL SYSTEMS TECHNICIAN / HVAC SERVICE TECH/HVAC INSTALL / SERVICE
- GLAZIER
- HEAVY EQUIPMENT OPERATOR / OPERATING ENGINEER
- INSULATION WORKER (HEAT and FROST)
- IRON WORKER
- IRON WORKER (ASSEMBLER, METAL BLDGS)
- PAINTER and DECORATOR
- PLASTERER
- PLUMBER
- RESIDENTIAL ELECTRICIAN
- ROOFER and WATER PROOFER
- SHEET METAL WORKER
- SPRINKLER FITTER
- STEAMFITTER
- STEAMFITTER (REFRIGERATION)
- STEAMFITTER (SERVICE)
- TAPER and FINISHER
- TELECOMMUNICATIONS (VOICE, DATA and VIDEO) INSTALLER-TECHNICIAN
- TILE SETTER

MCPIKE PARK SKATEPARK SEATING AREA

CONTRACT NO. 8273

DATE: 9/20

Raymond P. Cattell, Inc.

Item	Quantity	Price	Extension
Section B: Proposal Page			
10911.0 - MOBILIZATION - LS	1.00	\$6,000.00	\$6,000.00
20101.0 - EXCAVATION CUT - CY	27.00	\$90.00	\$2,430.00
20201.0 - FILL BORROW - CY	36.00	\$100.00	\$3,600.00
20217.0 - CLEAR STONE - TON	35.00	\$30.00	\$1,050.00
20221.0 - TOPSOIL - SY	107.00	\$10.00	\$1,070.00
20701.0 - TERRACE SEEDING - SY	360.00	\$7.00	\$2,520.00
21011.0 - CONSTRUCTION ENTRANCE - EA	1.00	\$400.00	\$400.00
21013.0 - STREET SWEEPING - LS	1.00	\$500.00	\$500.00
21017.0 - SILT SOCK (8 INCH) - COMPLETE - LF	300.00	\$6.00	\$1,800.00
21061.0 - EROSION MATTING, CLASS I URBAN TYPE A - SY	360.00	\$7.00	\$2,520.00
40102.0 - CRUSHED AGGREGATE BASE COURSE GRADATION NO. 2 - TON	10.30	\$50.00	\$515.00
90000.0 - CONSTRUCTION FENCE (PLASTIC) - LF	150.00	\$5.00	\$750.00
90001.0 - THICKENED EDGE CONCRETE SLAB - LS	1.00	\$3,500.00	\$3,500.00
90002.0 - REMOVE AND RE-INSTALL EXISTING FENCE - LF	61.00	\$65.00	\$3,965.00
90003.0 - ORNAMENTAL METAL FENCE - LF	21.00	\$400.00	\$8,400.00
90004.0 - INSTALL BOULDER RETAINING WALL - LS	1.00	\$6,000.00	\$6,000.00
90005.0 - INSTALL PREFABRICATED BLEACHER - LS	1.00	\$2,000.00	\$2,000.00
17 Items	Totals		\$47,020.00



Department of Public Works
Engineering Division
 Robert F. Phillips, P.E., City Engineer
 City-County Building, Room 115
 210 Martin Luther King, Jr. Boulevard
 Madison, Wisconsin 53703
 Phone: (608) 266-4751
 Fax: (608) 264-9275
engineering@cityofmadison.com
www.cityofmadison.com/engineering

Assistant City Engineer
 Gregory T. Fries, P.E.
 Kathleen M. Cryan
Principal Engineer 2
 Christopher J. Petykowski, P.E.
 John S. Fahrney, P.E.
Principal Engineer 1
 Christina M. Bachmann, P.E.
 Mark D. Moder, P.E.
 Janet Schmidt, P.E.
Facilities & Sustainability
 Jeanne E. Hoffman, Manager
Mapping Section Manager
 Eric T. Pederson, P.S.
Financial Manager
 Steven B. Danner-Rivers

BIENNIAL BID BOND

Raymond P. Cattell, Inc.

(a corporation of the State of Wisconsin)
 (individual), (partnership), (hereinafter referred to as the "Principal") and
The Ohio Casualty Insurance Company

a corporation of the State of New Hampshire (hereinafter referred to as the "Surety") and licensed to do business in the State of Wisconsin, are held and firmly bound unto the City of Madison, Wisconsin (hereinafter referred to as the "City"), in the sum equal to the individual proposal guaranty amounts of the total bid or bids of the Principal herein accepted by the City, for the payment of which the Principal and the Surety hereby jointly and severally bind ourselves, our heirs, executors, administrators, successors and assigns.

The condition of this obligation is that the Principal has submitted to the City certain bids for projects from the time period of February 1, 2018 through February 1, 2020.

If the Principal is awarded the contract(s) by the City and, within the time and manner required by law after the prescribed forms are presented for its signature, the Principal enters into (a) written contract(s) in accordance with the bid(s), and files with the City its bond(s) guaranteeing faithful performance and payment for all labor and materials, as required by law, or if the City rejects all bids for the work described, then this obligation shall be null and void; otherwise, it shall remain in full force and effect.

In the event the Principal shall fail to execute and deliver the contract(s) or the performance and payment bond(s), all within the time specified or any extension thereof, the Principal and Surety agree jointly and severally to pay to the City within ten (10) calendar days of written demand a total equal to the sum of the individual proposal guaranty amounts of the total bid(s) as liquidated damages.

The Surety, for value received, hereby agrees that the obligations of it and its bond shall be in no way impaired or affected by any extension of time within which the City may accept a bid, and the Surety does hereby waive notice of any such extension.

This bond may be terminated by the Surety upon giving thirty (30) days written notice to the City of its intent to terminate this bond and to be released and discharged therefrom, but such termination shall not operate to relieve or discharge the Surety from any liability already accrued or which shall accrue before the expiration of such thirty (30) day period.

IN WITNESS WHEREOF, the Principal and the Surety have hereunto set their hands and seals, and such of them as are corporations have caused their corporate seals to be hereto affixed and these presents to be signed by their proper officers, on the day and year set forth below.

PRINCIPAL

Raymond P. Cattell
COMPANY NAME AFFIX SEAL

February 1, 2018
DATE

By: *Arthur Murray Sec*
SIGNATURE AND TITLE

SURETY

The Ohio Casualty Insurance Company
COMPANY NAME AFFIX SEAL

February 1, 2018
DATE

By: *Mike Al* Attorney-In-Fact
SIGNATURE AND TITLE

This certifies that I have been duly licensed as an agent for the Surety in Wisconsin under National Provider No. 14840439 for the year 2018 and appointed as attorney in fact with authority to execute this bid bond, which power of attorney has not been revoked.

February 1, 2018
DATE

Mike Al
AGENT SIGNATURE

828 John Nolen Drive
ADDRESS

Madison, WI 53713
CITY, STATE AND ZIP CODE

608-288-2893
TELEPHONE NUMBER

Note to Surety and Principal: Any bid submitted which this bond guarantees may be rejected if the Power of Attorney form showing that the Agent of Surety is currently authorized to execute bonds on behalf of Surety is not attached to this bond.

CERTIFICATE OF BIENNIAL BID BOND

TIME PERIOD- VALID (FROM/TO) February 1, 2018 - February 1, 2020
NAME OF SURETY The Ohio Casualty Insurance Company
NAME OF CONTRACTOR Raymond P. Cattell, Inc.
CERTIFICATE HOLDER City of Madison, Wisconsin

This is to certify that a biennial bid bond issued by the above-named Surety is currently on file with the City of Madison.

This certificate is issued as a matter of information and conveys no rights upon the certificate holder and does not amend, extend or alter the coverage of the biennial bid bond.

Cancellation: Should the above policy be cancelled before the expiration date, the issuing Surety will give thirty (30) days written notice to the certificate holder indicated above.



 SIGNATURE OF AUTHORIZED CONTRACTOR REPRESENTATIVE

February 1, 2018

 DATE

THIS POWER OF ATTORNEY IS NOT VALID UNLESS IT IS PRINTED ON RED BACKGROUND.

This Power of Attorney limits the acts of those named herein, and they have no authority to bind the Company except in the manner and to the extent herein stated.

Certificate No. 7989373

Liberty Mutual Insurance Company
The Ohio Casualty Insurance Company West American Insurance Company

POWER OF ATTORNEY

KNOWN ALL PERSONS BY THESE PRESENTS: That The Ohio Casualty Insurance Company is a corporation duly organized under the laws of the State of New Hampshire, that Liberty Mutual Insurance Company is a corporation duly organized under the laws of the State of Massachusetts, and West American Insurance Company is a corporation duly organized under the laws of the State of Indiana (herein collectively called the "Companies"), pursuant to and by authority herein set forth, does hereby name, constitute and appoint, Michael J. Moore; Travis Schreiber; Richard F. Kekula; Kim E. Schwenn; Trisha Stark; Michael R. Zahn; Julie Zimmerman

all of the city of Madison, state of WI each individually if there be more than one named, its true and lawful attorney-in-fact to make, execute, seal, acknowledge and deliver, for and on its behalf as surety and as its act and deed, any and all undertakings, bonds, recognizances and other surety obligations, in pursuance of these presents and shall be as binding upon the Companies as if they have been duly signed by the president and attested by the secretary of the Companies in their own proper persons.

IN WITNESS WHEREOF, this Power of Attorney has been subscribed by an authorized officer or official of the Companies and the corporate seals of the Companies have been affixed thereto this 24th day of January, 2018



The Ohio Casualty Insurance Company
Liberty Mutual Insurance Company
West American Insurance Company

By: David M. Carey
David M. Carey, Assistant Secretary

STATE OF PENNSYLVANIA ss
COUNTY OF MONTGOMERY

On this 24th day of January, 2018, before me personally appeared David M. Carey, who acknowledged himself to be the Assistant Secretary of Liberty Mutual Insurance Company, The Ohio Casualty Company, and West American Insurance Company, and that he, as such, being authorized so to do, execute the foregoing instrument for the purposes therein contained by signing on behalf of the corporations by himself as a duly authorized officer.

IN WITNESS WHEREOF, I have hereunto subscribed my name and affixed my notarial seal at King of Prussia, Pennsylvania, on the day and year first above written.



COMMONWEALTH OF PENNSYLVANIA
Notarial Seal
Teresa Pastella, Notary Public
Upper Merion Twp., Montgomery County
My Commission Expires March 28, 2021
Member, Pennsylvania Association of Notaries

By: Teresa Pastella
Teresa Pastella, Notary Public

This Power of Attorney is made and executed pursuant to and by authority of the following By-laws and Authorizations of The Ohio Casualty Insurance Company, Liberty Mutual Insurance Company, and West American Insurance Company which resolutions are now in full force and effect reading as follows:

ARTICLE IV – OFFICERS – Section 12. Power of Attorney. Any officer or other official of the Corporation authorized for that purpose in writing by the Chairman or the President, and subject to such limitation as the Chairman or the President may prescribe, shall appoint such attorneys-in-fact, as may be necessary to act in behalf of the Corporation to make, execute, seal, acknowledge and deliver as surety any and all undertakings, bonds, recognizances and other surety obligations. Such attorneys-in-fact, subject to the limitations set forth in their respective powers of attorney, shall have full power to bind the Corporation by their signature and execution of any such instruments and to attach thereto the seal of the Corporation. When so executed, such instruments shall be as binding as if signed by the President and attested to by the Secretary. Any power or authority granted to any representative or attorney-in-fact under the provisions of this article may be revoked at any time by the Board, the Chairman, the President or by the officer or officers granting such power or authority.

ARTICLE XIII – Execution of Contracts – SECTION 5. Surety Bonds and Undertakings. Any officer of the Company authorized for that purpose in writing by the chairman or the president, and subject to such limitations as the chairman or the president may prescribe, shall appoint such attorneys-in-fact, as may be necessary to act in behalf of the Company to make, execute, seal, acknowledge and deliver as surety any and all undertakings, bonds, recognizances and other surety obligations. Such attorneys-in-fact subject to the limitations set forth in their respective powers of attorney, shall have full power to bind the Company by their signature and execution of any such instruments and to attach thereto the seal of the Company. When so executed such instruments shall be as binding as if signed by the president and attested by the secretary.

Certificate of Designation – The President of the Company, acting pursuant to the Bylaws of the Company, authorizes David M. Carey, Assistant Secretary to appoint such attorneys-in-fact as may be necessary to act on behalf of the Company to make, execute, seal, acknowledge and deliver as surety any and all undertakings, bonds, recognizances and other surety obligations.

Authorization – By unanimous consent of the Company's Board of Directors, the Company consents that facsimile or mechanically reproduced signature of any assistant secretary of the Company, wherever appearing upon a certified copy of any power of attorney issued by the Company in connection with surety bonds, shall be valid and binding upon the Company with the same force and effect as though manually affixed.

I, Renee C. Llewellyn, the undersigned, Assistant Secretary, The Ohio Casualty Insurance Company, Liberty Mutual Insurance Company, and West American Insurance Company do hereby certify that the original power of attorney of which the foregoing is a full, true and correct copy of the Power of Attorney executed by said Companies, is in full force and effect and has not been revoked.

IN TESTIMONY WHEREOF, I have hereunto set my hand and affixed the seals of said Companies this 1st day of February, 2018



By: Renee C. Llewellyn
Renee C. Llewellyn, Assistant Secretary

currency rate, interest rate or residual value guarantees.

To confirm the validity of this Power of Attorney call 1-610-832-8240 between 9:00 am and 4:30 pm EST on any business day.

SECTION H: AGREEMENT

THIS AGREEMENT made this 17 day of October in the year Two Thousand and Eighteen between RAYMOND P. CATTELL, INC. hereinafter called the Contractor, and the City of Madison, Wisconsin, hereinafter called the City.

WHEREAS, the Common Council of the said City of Madison under the provisions of a resolution adopted OCTOBER 16, 2018, and by virtue of authority vested in the said Council, has awarded to the Contractor the work of performing certain construction.

NOW, THEREFORE, the Contractor and the City, for the consideration hereinafter named, agree as follows:

1. **Scope of Work.** The Contractor shall, perform the construction, execution and completion of the following listed complete work or improvement in full compliance with the Plans, Specifications, Standard Specifications, Supplemental Specifications, Special Provisions and contract; perform all items of work covered or stipulated in the proposal; perform all altered or extra work; and shall furnish, unless otherwise provided in the contract, all materials, implements, machinery, equipment, tools, supplies, transportation, and labor necessary to the prosecution and completion of the work or improvements:

MCPIKE PARK – SKATEPARK SEATING AREA
CONTRACT NO. 8273

2. **Completion Date/Contract Time.** Construction work must begin within seven (7) calendar days after the date appearing on mailed written notice to do so shall have been sent to the Contractor and shall be carried on at a rate so as to secure full completion SEE SPECIAL PROVISIONS, the rate of progress and the time of completion being essential conditions of this Agreement.
3. **Contract Price.** The City shall pay to the Contractor at the times, in the manner and on the conditions set forth in said specifications, the sum of FORTY-SEVEN THOUSAND TWENTY AND NO/100 (\$47,020.00) Dollars being the amount bid by such Contractor and which was awarded to him/her as provided by law.
4. **Affirmative Action.** In the performance of the services under this Agreement the Contractor agrees not to discriminate against any employee or applicant because of race, religion, marital status, age, color, sex, disability, national origin or ancestry, income level or source of income, arrest record or conviction record, less than honorable discharge, physical appearance, sexual orientation, gender identity, political beliefs, or student status. The Contractor further agrees not to discriminate against any subcontractor or person who offers to subcontract on this contract because of race, religion, color, age, disability, sex, sexual orientation, gender identity or national origin.

The Contractor agrees that within thirty (30) days after the effective date of this agreement, the Contractor will provide to the City Affirmative Action Division certain workforce utilization statistics, using a form to be furnished by the City.

If the contract is still in effect, or if the City enters into a new agreement with the Contractor, within one year after the date on which the form was required to be provided, the Contractor will provide updated workforce information using a second form, also to be furnished by the City. The second form will be submitted to the City Affirmative Action Division no later than one year after the date on which the first form was required to be provided.

The Contractor further agrees that, for at least twelve (12) months after the effective date of this contract, it will notify the City Affirmative Action Division of each of its job openings at facilities in Dane County for which applicants not already employees of the Contractor are to be considered. The notice will include a job description, classification, qualification and application procedures

and deadlines. The Contractor agrees to interview and consider candidates referred by the Affirmative Action Division if the candidate meets the minimum qualification standards established by the Contractor, and if the referral is timely. A referral is timely if it is received by the Contractor on or before the date started in the notice.

Articles of Agreement

Article I

The Contractor shall take affirmative action in accordance with the provisions of this contract to insure that applicants are employed, and that employees are treated during employment without regard to race, religion, color, age, marital status, disability, sex, sexual orientation, gender identity or national origin and that the employer shall provide harassment free work environment for the realization of the potential of each employee. Such action shall include, but not be limited to, the following: employment, upgrading, demotion or transfer, recruitment or recruitment advertising, layoff or termination, rates of pay or other forms of compensation and selection for training including apprenticeship insofar as it is within the control of the Contractor. The Contractor agrees to post in conspicuous places available to employees and applicants notices to be provided by the City setting out the provisions of the nondiscrimination clauses in this contract.

Article II

The Contractor shall in all solicitations or advertisements for employees placed by or on behalf of the Contractors state that all qualified or qualifiable applicants will be employed without regard to race, religion, color, age, marital status, disability, sex, sexual orientation, gender identity or national origin.

Article III

The Contractor shall send to each labor union or representative of workers with which it has a collective bargaining agreement or other contract or understanding a notice to be provided by the City advising the labor union or worker's representative of the Contractor's equal employment opportunity and affirmative action commitments. Such notices shall be posted in conspicuous places available to employees and applicants for employment.

Article V

The Contractor agrees that it will comply with all provisions of the Affirmative Action Ordinance of the City of Madison, including the contract compliance requirements. The Contractor agrees to submit the model affirmative action plan for public works contractors in a form approved by the Affirmative Action Division Manager.

Article VI

The Contractor will maintain records as required by Section 39.02(9)(f) of the Madison General Ordinances and will provide the City Affirmative Action Division with access to such records and to persons who have relevant and necessary information, as provided in Section 39.02(9)(f). The City agrees to keep all such records confidential, except to the extent that public inspection is required by law.

Article VII

In the event of the Contractor's or subcontractor's failure to comply with the Equal Employment Opportunity and Affirmative Action Provisions of this contract or Section 39.03 and 39.02 of the Madison General Ordinances, it is agreed that the City at its option may do any or all of the following:

1. Cancel, terminate or suspend this Contract in whole or in part.

2. Declare the Contractor ineligible for further City contracts until the Affirmative Action requirements are met.
3. Recover on behalf of the City from the prime Contractor 0.5 percent of the contract award price for each week that such party fails or refuses to comply, in the nature of liquidated damages, but not to exceed a total of five percent (5%) of the contract price, or five thousand dollars (\$5,000), whichever is less. Under public works contracts, if a subcontractor is in noncompliance, the City may recover liquidated damages from the prime Contractor in the manner described above. The preceding sentence shall not be construed to prohibit a prime Contractor from recovering the amount of such damage from the non-complying subcontractor.

Article VIII

The Contractor shall include the above provisions of this contract in every subcontract so that such provisions will be binding upon each subcontractor. The Contractor shall take such action with respect to any subcontractor as necessary to enforce such provisions, including sanctions provided for noncompliance.

Article IX

The Contractor shall allow the maximum feasible opportunity to small business enterprises to compete for any subcontracts entered into pursuant to this contract. (In federally funded contracts the terms "DBE, MBE and WBE" shall be substituted for the term "small business" in this Article.)

5. Substance Abuse Prevention Program Required. Prior to commencing work on the Contract, the Contractor, and any Subcontractor, shall have in place a written program for the prevention of substance abuse among its employees as required under Wis. Stat. Sec. 103.503.
6. **Contractor Hiring Practices.**

Ban the Box - Arrest and Criminal Background Checks. (Sec. 39.08, MGO)

This provision applies to all prime contractors on contracts entered into on or after January 1, 2016, and all subcontractors who are required to meet prequalification requirements under MGO 33.07(7)(l), MGO as of the first time they seek or renew pre-qualification status on or after January 1, 2016. The City will monitor compliance of subcontractors through the pre-qualification process.

- a. **Definitions.** For purposes of this section, "Arrest and Conviction Record" includes, but is not limited to, information indicating that a person has been questioned, apprehended, taken into custody or detention, held for investigation, arrested, charged with, indicted or tried for any felony, misdemeanor or other offense pursuant to any law enforcement or military authority.

"Conviction record" includes, but is not limited to, information indicating that a person has been convicted of a felony, misdemeanor or other offense, placed on probation, fined, imprisoned or paroled pursuant to any law enforcement or military authority.

"Background Check" means the process of checking an applicant's arrest and conviction record, through any means.

- b. **Requirements.** For the duration of this Contract, the Contractor shall:
 1. Remove from all job application forms any questions, check boxes, or other inquiries regarding an applicant's arrest and conviction record, as defined herein.

2. Refrain from asking an applicant in any manner about their arrest or conviction record until after conditional offer of employment is made to the applicant in question.
3. Refrain from conducting a formal or informal background check or making any other inquiry using any privately or publicly available means of obtaining the arrest or conviction record of an applicant until after a conditional offer of employment is made to the applicant in question.
4. Make information about this ordinance available to applicants and existing employees, and post notices in prominent locations at the workplace with information about the ordinance and complaint procedure using language provided by the City.
5. Comply with all other provisions of Sec. 39.08, MGO.

c. Exemptions: This section shall not apply when:

1. Hiring for a position where certain convictions or violations are a bar to employment in that position under applicable law, or
2. Hiring a position for which information about criminal or arrest record, or a background check is required by law to be performed at a time or in a manner that would otherwise be prohibited by this ordinance, including a licensed trade or profession where the licensing authority explicitly authorizes or requires the inquiry in question.

To be exempt, Contractor has the burden of demonstrating that there is an applicable law or regulation that requires the hiring practice in question, if so, the contractor is exempt from all of the requirements of this ordinance for the position(s) in question.

MCPIKE PARK – SKATEPARK SEATING AREA
CONTRACT NO. 8273

IN WITNESS WHEREOF, the Contractor has hereunto set his/her hand and seal and the City has caused these presents to be sealed with its corporate seal and to be subscribed by its Mayor and City Clerk the day and year first above written.

Countersigned:

RAYMOND P. CATTELL, INC.

Company Name

<u>[Signature]</u>	<u>10-17-18</u>	<u>[Signature]</u>	<u>10-17-2018</u>
Witness	Date	President	Date
<u>[Signature]</u>	<u>10-17-18</u>	<u>[Signature]</u>	<u>10-17-2018</u>
Witness	Date	Secretary	Date

CITY OF MADISON, WISCONSIN

Provisions have been made to pay the liability that will accrue under this contract.

Approved as to form:

[Signature]
Finance Director

[Signature]
City Attorney

Signed this _____ day of _____, 20_____

[Signature]
Witness

[Signature] November 2, 2018
Mayor Date

[Signature]
Witness

[Signature] 10-23-18
City Clerk Date

SECTION I: PAYMENT AND PERFORMANCE BOND

KNOW ALL MEN BY THESE PRESENTS, that we RAYMOND P. CATTELL, INC. as principal, and The Ohio Casualty Insurance Company Company of New Hampshire as surety, are held and firmly bound unto the City of Madison, Wisconsin, in the sum of FORTY-SEVEN THOUSAND TWENTY AND NO/100 (\$47,020.00) Dollars, lawful money of the United States, for the payment of which sum to the City of Madison, we hereby bind ourselves and our respective executors and administrators firmly by these presents.

The condition of this Bond is such that if the above bounden shall on his/her part fully and faithfully perform all of the terms of the Contract entered into between him/herself and the City of Madison for the construction of:

MCPIKE PARK – SKATEPARK SEATING AREA
CONTRACT NO. 8273

in Madison, Wisconsin, and shall pay all claims for labor performed and material furnished in the prosecution of said work, and save the City harmless from all claims for damages because of negligence in the prosecution of said work, and shall save harmless the said City from all claims for compensation (under Chapter 102, Wisconsin Statutes) of employees and employees of subcontractor, then this Bond is to be void, otherwise of full force, virtue and effect.

Signed and sealed this 17th day of October, 2018

Countersigned:

RAYMOND P. CATTELL, INC.
Company Name (Principal)

[Signature]
Witness
[Signature]
Secretary

[Signature]
President Seal

Approved as to form:

The Ohio Casualty Insurance Company
Surety Seal
 Salary Employee Commission

[Signature]
City Attorney

By [Signature]
Attorney-in-Fact Michael R. Zahn

This certifies that I have been duly licensed as an agent for the above company in Wisconsin under National Producer Number 14840439 for the year 2018, and appointed as attorney-in-fact with authority to execute this payment and performance bond which power of attorney has not been revoked.

October 17, 2018
Date

[Signature]
Agent Signature Michael R. Zahn

5

THIS POWER OF ATTORNEY IS NOT VALID UNLESS IT IS PRINTED ON RED BACKGROUND.

This Power of Attorney limits the acts of those named herein, and they have no authority to bind the Company except in the manner and to the extent herein stated.

Certificate No. 7989478

Liberty Mutual Insurance Company
The Ohio Casualty Insurance Company West American Insurance Company

POWER OF ATTORNEY

KNOWN ALL PERSONS BY THESE PRESENTS: That The Ohio Casualty Insurance Company is a corporation duly organized under the laws of the State of New Hampshire, that Liberty Mutual Insurance Company is a corporation duly organized under the laws of the State of Massachusetts, and West American Insurance Company is a corporation duly organized under the laws of the State of Indiana (herein collectively called the "Companies"), pursuant to and by authority herein set forth, does hereby name, constitute and appoint, Michael J. Moore; Travis Schreiber; Richard F. Kekula; Kim E. Schwenn; Trisha Stark; Michael R. Zahn; Julie Zimmerman

all of the city of Madison, state of WI each individually if there be more than one named, its true and lawful attorney-in-fact to make, execute, seal, acknowledge and deliver, for and on its behalf as surety and as its act and deed, any and all undertakings, bonds, recognizances and other surety obligations, in pursuance of these presents and shall be as binding upon the Companies as if they have been duly signed by the president and attested by the secretary of the Companies in their own proper persons.

IN WITNESS WHEREOF, this Power of Attorney has been subscribed by an authorized officer or official of the Companies and the corporate seals of the Companies have been affixed thereto this 24th day of January, 2018.



The Ohio Casualty Insurance Company
Liberty Mutual Insurance Company
West American Insurance Company

By: David M. Carey
David M. Carey, Assistant Secretary

STATE OF PENNSYLVANIA ss
COUNTY OF MONTGOMERY

On this 24th day of January, 2018, before me personally appeared David M. Carey, who acknowledged himself to be the Assistant Secretary of Liberty Mutual Insurance Company, The Ohio Casualty Company, and West American Insurance Company, and that he, as such, being authorized so to do, execute the foregoing instrument for the purposes therein contained by signing on behalf of the corporations by himself as a duly authorized officer.

IN WITNESS WHEREOF, I have hereunto subscribed my name and affixed my notarial seal at King of Prussia, Pennsylvania, on the day and year first above written.



COMMONWEALTH OF PENNSYLVANIA
Notarial Seal
Teresa Pastella, Notary Public
Upper Merion Twp., Montgomery County
My Commission Expires March 28, 2021
Member, Pennsylvania Association of Notaries

By: Teresa Pastella
Teresa Pastella, Notary Public

This Power of Attorney is made and executed pursuant to and by authority of the following By-laws and Authorizations of The Ohio Casualty Insurance Company, Liberty Mutual Insurance Company, and West American Insurance Company which resolutions are now in full force and effect reading as follows:

ARTICLE IV – OFFICERS – Section 12. Power of Attorney. Any officer or other official of the Corporation authorized for that purpose in writing by the Chairman or the President, and subject to such limitation as the Chairman or the President may prescribe, shall appoint such attorneys-in-fact, as may be necessary to act in behalf of the Corporation to make, execute, seal, acknowledge and deliver as surety any and all undertakings, bonds, recognizances and other surety obligations. Such attorneys-in-fact, subject to the limitations set forth in their respective powers of attorney, shall have full power to bind the Corporation by their signature and execution of any such instruments and to attach thereto the seal of the Corporation. When so executed, such instruments shall be as binding as if signed by the President and attested to by the Secretary. Any power or authority granted to any representative or attorney-in-fact under the provisions of this article may be revoked at any time by the Board, the Chairman, the President or by the officer or officers granting such power or authority.

ARTICLE XIII – Execution of Contracts – SECTION 5. Surety Bonds and Undertakings. Any officer of the Company authorized for that purpose in writing by the chairman or the president, and subject to such limitations as the chairman or the president may prescribe, shall appoint such attorneys-in-fact, as may be necessary to act in behalf of the Company to make, execute, seal, acknowledge and deliver as surety any and all undertakings, bonds, recognizances and other surety obligations. Such attorneys-in-fact subject to the limitations set forth in their respective powers of attorney, shall have full power to bind the Company by their signature and execution of any such instruments and to attach thereto the seal of the Company. When so executed such instruments shall be as binding as if signed by the president and attested by the secretary.

Certificate of Designation – The President of the Company, acting pursuant to the Bylaws of the Company, authorizes David M. Carey, Assistant Secretary to appoint such attorneys-in-fact as may be necessary to act on behalf of the Company to make, execute, seal, acknowledge and deliver as surety any and all undertakings, bonds, recognizances and other surety obligations.

Authorization – By unanimous consent of the Company's Board of Directors, the Company consents that facsimile or mechanically reproduced signature of any assistant secretary of the Company, wherever appearing upon a certified copy of any power of attorney issued by the Company in connection with surety bonds, shall be valid and binding upon the Company with the same force and effect as though manually affixed.

I, Renee C. Llewellyn, the undersigned, Assistant Secretary, The Ohio Casualty Insurance Company, Liberty Mutual Insurance Company, and West American Insurance Company do hereby certify that the original power of attorney of which the foregoing is a full, true and correct copy of the Power of Attorney executed by said Companies, is in full force and effect and has not been revoked.

IN TESTIMONY WHEREOF, I have hereunto set my hand and affixed the seals of said Companies this 17th day of October, 2018.



By: Renee C. Llewellyn
Renee C. Llewellyn, Assistant Secretary

Not valid for mortgage, note, loan, letter of credit, currency rate, interest rate or residual value guarantees.

To confirm the validity of this Power of Attorney call 1-610-832-8240 between 9:00 am and 4:30 pm EST on any business day.

